

Official SAT[®] Practice Test 2011-12

Taking the Practice Test

The practice test will help you most if you take it under conditions as close as possible to those of the actual test.

- **Set aside 3 hours and 20 minutes of uninterrupted time**
That way you can complete the entire test in one sitting. *Note:* The total testing time is 3 hours and 45 minutes, but you save 25 minutes because the unscored section* from this practice test was omitted.
- **Sit at a desk or table cleared of any other papers or books**
You won't be able to take a dictionary, books, notes, or scratch paper into the test room.
- **Allow yourself the specified amount of time for each section**
Pace yourself by using a watch (without an audible alarm), which is what you are allowed to use on test day.
- **Have a calculator at hand when you take the math sections**
This will help you determine how much to use a calculator the day of the test. Use a calculator with which you are familiar—preferably the same calculator you will use on test day.
- **Read the test instructions carefully**
They are reprinted from the back cover of the test book. On test day, you will be asked to read them before you begin answering questions.
- **Make sure you use a No. 2 pencil**
It is very important that you fill in the entire circle on the answer sheet darkly and completely. If you change your response, erase it as completely as possible. It is very important that you follow these instructions when filling out your answer sheet.
- **Record your answers on paper, then score your test**
Use the answer sheet when completing a practice test on paper to simulate the real testing environment. After completing the practice test, you can score the test yourself with “Scoring Your Test,” or you can return to collegeboard.com to enter your answers online and receive a score report and answer explanations.

YOUR NAME (PRINT) _____ LAST FIRST MI

TEST CENTER _____ NUMBER NAME OF TEST CENTER ROOM NUMBER

SAT — General Directions

Timing

- You will have 3 hours and 45 minutes to work on this test.
- There are ten separately timed sections:
 - ▶ One 25-minute essay
 - ▶ Six other 25-minute sections
 - ▶ Two 20-minute sections
 - ▶ One 10-minute section
- You may work on only one section at a time.
- The supervisor will tell you when to begin and end each section.
- If you finish a section before time is called, check your work on that section. You may NOT turn to any other section.
- Work as rapidly as you can without losing accuracy. Don't waste time on questions that seem too difficult for you.

Marking Answers

- Be sure to mark your answer sheet properly.

COMPLETE MARK ● EXAMPLES OF INCOMPLETE MARKS 

- You must use a No. 2 pencil.
- Carefully mark only one answer for each question.
- Make sure you fill the entire circle darkly and completely.
- Do not make any stray marks on your answer sheet.
- If you erase, do so completely. Incomplete erasures may be scored as intended answers.
- Use only the answer spaces that correspond to the question numbers.

Using Your Test Book

- You may use the test book for scratch work, but you will not receive credit for anything that you write in your test book.
- After time has been called, you may not transfer answers from your test book to your answer sheet or fill in circles.
- You may not fold or remove pages or portions of a page from this book, or take the book or answer sheet from the testing room.

Scoring

- For each correct answer, you receive one point.
- For questions you omit, you receive no points.
- For a wrong answer to a multiple-choice question, you lose one-fourth of a point.
 - ▶ If you can eliminate one or more of the answer choices as wrong, you increase your chances of choosing the correct answer and earning one point.
 - ▶ If you can't eliminate any choice, move on. You can return to the question later if there is time.
- For a wrong answer to a student-produced response ("grid-in") math question, you don't lose any points.
- Multiple-choice and student-produced response questions are machine scored.
- The essay is scored on a 1 to 6 scale by two different readers. The total essay score is the sum of the two readers' scores.
- Off-topic essays, blank essays, and essays written in ink will receive a score of zero.
- If your essay does not reflect your original and individual work, your test scores may be canceled.

The passages for this test have been adapted from published material. The ideas contained in them do not necessarily represent the opinions of the College Board.

IMPORTANT: The codes below are unique to your test book. Copy them on your answer sheet in boxes 8 and 9 and fill in the corresponding circles exactly as shown.

9	TEST FORM <small>(Copy from back of test book.)</small>					
	1	9	0	1	0	1

8	FORM CODE <small>(Copy and grid as on back of test book.)</small>					
	A	E	F	A	0	1
●	(A)	(A)	●	(0)	(0)	
(B)	(B)	(B)	(1)	●	(1)	
(C)	(C)	(C)	(2)	(2)	●	
(D)	(D)	(D)	(3)	(3)	(3)	
(E)	●	(E)	(4)	(4)	(4)	
(F)	(F)	●	(5)	(5)	(5)	
(G)	(G)	(G)	(6)	(6)	(6)	
(H)	(H)	(H)	(7)	(7)	(7)	
(I)	(I)	(I)	(8)	(8)	(8)	
(J)	(J)	(J)	(9)	(9)	(9)	
(K)	(K)	(K)				
(L)	(L)	(L)				
(M)	(M)	(M)				
(N)	(N)	(N)				
(O)	(O)	(O)				
(P)	(P)	(P)				
(Q)	(Q)	(Q)				
(R)	(R)	(R)				
(S)	(S)	(S)				
(T)	(T)	(T)				
(U)	(U)	(U)				
(V)	(V)	(V)				
(W)	(W)	(W)				
(X)	(X)	(X)				
(Y)	(Y)	(Y)				
(Z)	(Z)	(Z)				

DO NOT OPEN THIS BOOK UNTIL THE SUPERVISOR TELLS YOU TO DO SO.

SECTION

1

I prefer NOT to grant the College Board the right to use, reproduce, or publish my essay for any purpose beyond the assessment of my writing skills, even though my name will not be used in any way in conjunction with my essay. I understand that I am free to mark this circle with no effect on my score.

IMPORTANT: USE A NO. 2 PENCIL. DO NOT WRITE OUTSIDE THE BORDER!
Words written outside the essay box or written in ink **WILL NOT APPEAR** in the copy sent to be scored, and your score will be affected.

Begin your essay on this page. If you need more space, continue on the next page.

Large rectangular area with horizontal lines for writing an essay.



COMPLETE MARK EXAMPLES OF INCOMPLETE MARKS

You must use a No. 2 pencil and marks must be complete. Do not use a mechanical pencil. It is very important that you fill in the entire circle darkly and completely. If you change your response, erase as completely as possible. Incomplete marks or erasures may affect your score.

SECTION 4

1	<input type="radio"/> A <input type="radio"/> B <input type="radio"/> C <input type="radio"/> D <input type="radio"/> E	11	<input type="radio"/> A <input type="radio"/> B <input type="radio"/> C <input type="radio"/> D <input type="radio"/> E	21	<input type="radio"/> A <input type="radio"/> B <input type="radio"/> C <input type="radio"/> D <input type="radio"/> E	31	<input type="radio"/> A <input type="radio"/> B <input type="radio"/> C <input type="radio"/> D <input type="radio"/> E
2	<input type="radio"/> A <input type="radio"/> B <input type="radio"/> C <input type="radio"/> D <input type="radio"/> E	12	<input type="radio"/> A <input type="radio"/> B <input type="radio"/> C <input type="radio"/> D <input type="radio"/> E	22	<input type="radio"/> A <input type="radio"/> B <input type="radio"/> C <input type="radio"/> D <input type="radio"/> E	32	<input type="radio"/> A <input type="radio"/> B <input type="radio"/> C <input type="radio"/> D <input type="radio"/> E
3	<input type="radio"/> A <input type="radio"/> B <input type="radio"/> C <input type="radio"/> D <input type="radio"/> E	13	<input type="radio"/> A <input type="radio"/> B <input type="radio"/> C <input type="radio"/> D <input type="radio"/> E	23	<input type="radio"/> A <input type="radio"/> B <input type="radio"/> C <input type="radio"/> D <input type="radio"/> E	33	<input type="radio"/> A <input type="radio"/> B <input type="radio"/> C <input type="radio"/> D <input type="radio"/> E
4	<input type="radio"/> A <input type="radio"/> B <input type="radio"/> C <input type="radio"/> D <input type="radio"/> E	14	<input type="radio"/> A <input type="radio"/> B <input type="radio"/> C <input type="radio"/> D <input type="radio"/> E	24	<input type="radio"/> A <input type="radio"/> B <input type="radio"/> C <input type="radio"/> D <input type="radio"/> E	34	<input type="radio"/> A <input type="radio"/> B <input type="radio"/> C <input type="radio"/> D <input type="radio"/> E
5	<input type="radio"/> A <input type="radio"/> B <input type="radio"/> C <input type="radio"/> D <input type="radio"/> E	15	<input type="radio"/> A <input type="radio"/> B <input type="radio"/> C <input type="radio"/> D <input type="radio"/> E	25	<input type="radio"/> A <input type="radio"/> B <input type="radio"/> C <input type="radio"/> D <input type="radio"/> E	35	<input type="radio"/> A <input type="radio"/> B <input type="radio"/> C <input type="radio"/> D <input type="radio"/> E
6	<input type="radio"/> A <input type="radio"/> B <input type="radio"/> C <input type="radio"/> D <input type="radio"/> E	16	<input type="radio"/> A <input type="radio"/> B <input type="radio"/> C <input type="radio"/> D <input type="radio"/> E	26	<input type="radio"/> A <input type="radio"/> B <input type="radio"/> C <input type="radio"/> D <input type="radio"/> E	36	<input type="radio"/> A <input type="radio"/> B <input type="radio"/> C <input type="radio"/> D <input type="radio"/> E
7	<input type="radio"/> A <input type="radio"/> B <input type="radio"/> C <input type="radio"/> D <input type="radio"/> E	17	<input type="radio"/> A <input type="radio"/> B <input type="radio"/> C <input type="radio"/> D <input type="radio"/> E	27	<input type="radio"/> A <input type="radio"/> B <input type="radio"/> C <input type="radio"/> D <input type="radio"/> E	37	<input type="radio"/> A <input type="radio"/> B <input type="radio"/> C <input type="radio"/> D <input type="radio"/> E
8	<input type="radio"/> A <input type="radio"/> B <input type="radio"/> C <input type="radio"/> D <input type="radio"/> E	18	<input type="radio"/> A <input type="radio"/> B <input type="radio"/> C <input type="radio"/> D <input type="radio"/> E	28	<input type="radio"/> A <input type="radio"/> B <input type="radio"/> C <input type="radio"/> D <input type="radio"/> E	38	<input type="radio"/> A <input type="radio"/> B <input type="radio"/> C <input type="radio"/> D <input type="radio"/> E
9	<input type="radio"/> A <input type="radio"/> B <input type="radio"/> C <input type="radio"/> D <input type="radio"/> E	19	<input type="radio"/> A <input type="radio"/> B <input type="radio"/> C <input type="radio"/> D <input type="radio"/> E	29	<input type="radio"/> A <input type="radio"/> B <input type="radio"/> C <input type="radio"/> D <input type="radio"/> E	39	<input type="radio"/> A <input type="radio"/> B <input type="radio"/> C <input type="radio"/> D <input type="radio"/> E
10	<input type="radio"/> A <input type="radio"/> B <input type="radio"/> C <input type="radio"/> D <input type="radio"/> E	20	<input type="radio"/> A <input type="radio"/> B <input type="radio"/> C <input type="radio"/> D <input type="radio"/> E	30	<input type="radio"/> A <input type="radio"/> B <input type="radio"/> C <input type="radio"/> D <input type="radio"/> E	40	<input type="radio"/> A <input type="radio"/> B <input type="radio"/> C <input type="radio"/> D <input type="radio"/> E

SECTION 5

1	<input type="radio"/> A <input type="radio"/> B <input type="radio"/> C <input type="radio"/> D <input type="radio"/> E	11	<input type="radio"/> A <input type="radio"/> B <input type="radio"/> C <input type="radio"/> D <input type="radio"/> E	21	<input type="radio"/> A <input type="radio"/> B <input type="radio"/> C <input type="radio"/> D <input type="radio"/> E	31	<input type="radio"/> A <input type="radio"/> B <input type="radio"/> C <input type="radio"/> D <input type="radio"/> E
2	<input type="radio"/> A <input type="radio"/> B <input type="radio"/> C <input type="radio"/> D <input type="radio"/> E	12	<input type="radio"/> A <input type="radio"/> B <input type="radio"/> C <input type="radio"/> D <input type="radio"/> E	22	<input type="radio"/> A <input type="radio"/> B <input type="radio"/> C <input type="radio"/> D <input type="radio"/> E	32	<input type="radio"/> A <input type="radio"/> B <input type="radio"/> C <input type="radio"/> D <input type="radio"/> E
3	<input type="radio"/> A <input type="radio"/> B <input type="radio"/> C <input type="radio"/> D <input type="radio"/> E	13	<input type="radio"/> A <input type="radio"/> B <input type="radio"/> C <input type="radio"/> D <input type="radio"/> E	23	<input type="radio"/> A <input type="radio"/> B <input type="radio"/> C <input type="radio"/> D <input type="radio"/> E	33	<input type="radio"/> A <input type="radio"/> B <input type="radio"/> C <input type="radio"/> D <input type="radio"/> E
4	<input type="radio"/> A <input type="radio"/> B <input type="radio"/> C <input type="radio"/> D <input type="radio"/> E	14	<input type="radio"/> A <input type="radio"/> B <input type="radio"/> C <input type="radio"/> D <input type="radio"/> E	24	<input type="radio"/> A <input type="radio"/> B <input type="radio"/> C <input type="radio"/> D <input type="radio"/> E	34	<input type="radio"/> A <input type="radio"/> B <input type="radio"/> C <input type="radio"/> D <input type="radio"/> E
5	<input type="radio"/> A <input type="radio"/> B <input type="radio"/> C <input type="radio"/> D <input type="radio"/> E	15	<input type="radio"/> A <input type="radio"/> B <input type="radio"/> C <input type="radio"/> D <input type="radio"/> E	25	<input type="radio"/> A <input type="radio"/> B <input type="radio"/> C <input type="radio"/> D <input type="radio"/> E	35	<input type="radio"/> A <input type="radio"/> B <input type="radio"/> C <input type="radio"/> D <input type="radio"/> E
6	<input type="radio"/> A <input type="radio"/> B <input type="radio"/> C <input type="radio"/> D <input type="radio"/> E	16	<input type="radio"/> A <input type="radio"/> B <input type="radio"/> C <input type="radio"/> D <input type="radio"/> E	26	<input type="radio"/> A <input type="radio"/> B <input type="radio"/> C <input type="radio"/> D <input type="radio"/> E	36	<input type="radio"/> A <input type="radio"/> B <input type="radio"/> C <input type="radio"/> D <input type="radio"/> E
7	<input type="radio"/> A <input type="radio"/> B <input type="radio"/> C <input type="radio"/> D <input type="radio"/> E	17	<input type="radio"/> A <input type="radio"/> B <input type="radio"/> C <input type="radio"/> D <input type="radio"/> E	27	<input type="radio"/> A <input type="radio"/> B <input type="radio"/> C <input type="radio"/> D <input type="radio"/> E	37	<input type="radio"/> A <input type="radio"/> B <input type="radio"/> C <input type="radio"/> D <input type="radio"/> E
8	<input type="radio"/> A <input type="radio"/> B <input type="radio"/> C <input type="radio"/> D <input type="radio"/> E	18	<input type="radio"/> A <input type="radio"/> B <input type="radio"/> C <input type="radio"/> D <input type="radio"/> E	28	<input type="radio"/> A <input type="radio"/> B <input type="radio"/> C <input type="radio"/> D <input type="radio"/> E	38	<input type="radio"/> A <input type="radio"/> B <input type="radio"/> C <input type="radio"/> D <input type="radio"/> E
9	<input type="radio"/> A <input type="radio"/> B <input type="radio"/> C <input type="radio"/> D <input type="radio"/> E	19	<input type="radio"/> A <input type="radio"/> B <input type="radio"/> C <input type="radio"/> D <input type="radio"/> E	29	<input type="radio"/> A <input type="radio"/> B <input type="radio"/> C <input type="radio"/> D <input type="radio"/> E	39	<input type="radio"/> A <input type="radio"/> B <input type="radio"/> C <input type="radio"/> D <input type="radio"/> E
10	<input type="radio"/> A <input type="radio"/> B <input type="radio"/> C <input type="radio"/> D <input type="radio"/> E	20	<input type="radio"/> A <input type="radio"/> B <input type="radio"/> C <input type="radio"/> D <input type="radio"/> E	30	<input type="radio"/> A <input type="radio"/> B <input type="radio"/> C <input type="radio"/> D <input type="radio"/> E	40	<input type="radio"/> A <input type="radio"/> B <input type="radio"/> C <input type="radio"/> D <input type="radio"/> E

CAUTION

Grid answers in the section below for **SECTION 4** or **SECTION 5** only if directed to do so in your test book.

Student-Produced Responses

ONLY ANSWERS THAT ARE GRIDDED WILL BE SCORED. YOU WILL NOT RECEIVE CREDIT FOR ANYTHING WRITTEN IN THE BOXES.

Quality Assurance Mark

SECT. 4 OR 5 ONLY

9		10		11		12		13	
14		15		16		17		18	

COMPLETE MARK ●

EXAMPLES OF INCOMPLETE MARKS



You must use a No. 2 pencil and marks must be complete. Do not use a mechanical pencil. It is very important that you fill in the entire circle darkly and completely. If you change your response, erase as completely as possible. Incomplete marks or erasures may affect your score.

SECTION 6

- 1 (A) (B) (C) (D) (E)
- 2 (A) (B) (C) (D) (E)
- 3 (A) (B) (C) (D) (E)
- 4 (A) (B) (C) (D) (E)
- 5 (A) (B) (C) (D) (E)
- 6 (A) (B) (C) (D) (E)
- 7 (A) (B) (C) (D) (E)
- 8 (A) (B) (C) (D) (E)
- 9 (A) (B) (C) (D) (E)
- 10 (A) (B) (C) (D) (E)

- 11 (A) (B) (C) (D) (E)
- 12 (A) (B) (C) (D) (E)
- 13 (A) (B) (C) (D) (E)
- 14 (A) (B) (C) (D) (E)
- 15 (A) (B) (C) (D) (E)
- 16 (A) (B) (C) (D) (E)
- 17 (A) (B) (C) (D) (E)
- 18 (A) (B) (C) (D) (E)
- 19 (A) (B) (C) (D) (E)
- 20 (A) (B) (C) (D) (E)

- 21 (A) (B) (C) (D) (E)
- 22 (A) (B) (C) (D) (E)
- 23 (A) (B) (C) (D) (E)
- 24 (A) (B) (C) (D) (E)
- 25 (A) (B) (C) (D) (E)
- 26 (A) (B) (C) (D) (E)
- 27 (A) (B) (C) (D) (E)
- 28 (A) (B) (C) (D) (E)
- 29 (A) (B) (C) (D) (E)
- 30 (A) (B) (C) (D) (E)

- 31 (A) (B) (C) (D) (E)
- 32 (A) (B) (C) (D) (E)
- 33 (A) (B) (C) (D) (E)
- 34 (A) (B) (C) (D) (E)
- 35 (A) (B) (C) (D) (E)
- 36 (A) (B) (C) (D) (E)
- 37 (A) (B) (C) (D) (E)
- 38 (A) (B) (C) (D) (E)
- 39 (A) (B) (C) (D) (E)
- 40 (A) (B) (C) (D) (E)

SECTION 7

- 1 (A) (B) (C) (D) (E)
- 2 (A) (B) (C) (D) (E)
- 3 (A) (B) (C) (D) (E)
- 4 (A) (B) (C) (D) (E)
- 5 (A) (B) (C) (D) (E)
- 6 (A) (B) (C) (D) (E)
- 7 (A) (B) (C) (D) (E)
- 8 (A) (B) (C) (D) (E)
- 9 (A) (B) (C) (D) (E)
- 10 (A) (B) (C) (D) (E)

- 11 (A) (B) (C) (D) (E)
- 12 (A) (B) (C) (D) (E)
- 13 (A) (B) (C) (D) (E)
- 14 (A) (B) (C) (D) (E)
- 15 (A) (B) (C) (D) (E)
- 16 (A) (B) (C) (D) (E)
- 17 (A) (B) (C) (D) (E)
- 18 (A) (B) (C) (D) (E)
- 19 (A) (B) (C) (D) (E)
- 20 (A) (B) (C) (D) (E)

- 21 (A) (B) (C) (D) (E)
- 22 (A) (B) (C) (D) (E)
- 23 (A) (B) (C) (D) (E)
- 24 (A) (B) (C) (D) (E)
- 25 (A) (B) (C) (D) (E)
- 26 (A) (B) (C) (D) (E)
- 27 (A) (B) (C) (D) (E)
- 28 (A) (B) (C) (D) (E)
- 29 (A) (B) (C) (D) (E)
- 30 (A) (B) (C) (D) (E)

- 31 (A) (B) (C) (D) (E)
- 32 (A) (B) (C) (D) (E)
- 33 (A) (B) (C) (D) (E)
- 34 (A) (B) (C) (D) (E)
- 35 (A) (B) (C) (D) (E)
- 36 (A) (B) (C) (D) (E)
- 37 (A) (B) (C) (D) (E)
- 38 (A) (B) (C) (D) (E)
- 39 (A) (B) (C) (D) (E)
- 40 (A) (B) (C) (D) (E)

CAUTION

Grid answers in the section below for SECTION 6 or SECTION 7 only if directed to do so in your test book.

Student-Produced Responses

ONLY ANSWERS THAT ARE GRIDDED WILL BE SCORED. YOU WILL NOT RECEIVE CREDIT FOR ANYTHING WRITTEN IN THE BOXES.

SECT. 6 OR 7 ONLY

9

1	0	0	0	0
2	1	1	1	1
3	2	2	2	2
4	3	3	3	3
5	4	4	4	4
6	5	5	5	5
7	6	6	6	6
8	7	7	7	7
9	8	8	8	8
	9	9	9	9

10

1	0	0	0	0
2	1	1	1	1
3	2	2	2	2
4	3	3	3	3
5	4	4	4	4
6	5	5	5	5
7	6	6	6	6
8	7	7	7	7
9	8	8	8	8
	9	9	9	9

11

1	0	0	0	0
2	1	1	1	1
3	2	2	2	2
4	3	3	3	3
5	4	4	4	4
6	5	5	5	5
7	6	6	6	6
8	7	7	7	7
9	8	8	8	8
	9	9	9	9

12

1	0	0	0	0
2	1	1	1	1
3	2	2	2	2
4	3	3	3	3
5	4	4	4	4
6	5	5	5	5
7	6	6	6	6
8	7	7	7	7
9	8	8	8	8
	9	9	9	9

13

1	0	0	0	0
2	1	1	1	1
3	2	2	2	2
4	3	3	3	3
5	4	4	4	4
6	5	5	5	5
7	6	6	6	6
8	7	7	7	7
9	8	8	8	8
	9	9	9	9

Quality Assurance Mark

14

1	0	0	0	0
2	1	1	1	1
3	2	2	2	2
4	3	3	3	3
5	4	4	4	4
6	5	5	5	5
7	6	6	6	6
8	7	7	7	7
9	8	8	8	8
	9	9	9	9

15

1	0	0	0	0
2	1	1	1	1
3	2	2	2	2
4	3	3	3	3
5	4	4	4	4
6	5	5	5	5
7	6	6	6	6
8	7	7	7	7
9	8	8	8	8
	9	9	9	9

16

1	0	0	0	0
2	1	1	1	1
3	2	2	2	2
4	3	3	3	3
5	4	4	4	4
6	5	5	5	5
7	6	6	6	6
8	7	7	7	7
9	8	8	8	8
	9	9	9	9

17

1	0	0	0	0
2	1	1	1	1
3	2	2	2	2
4	3	3	3	3
5	4	4	4	4
6	5	5	5	5
7	6	6	6	6
8	7	7	7	7
9	8	8	8	8
	9	9	9	9

18

1	0	0	0	0
2	1	1	1	1
3	2	2	2	2
4	3	3	3	3
5	4	4	4	4
6	5	5	5	5
7	6	6	6	6
8	7	7	7	7
9	8	8	8	8
	9	9	9	9

PLEASE DO NOT WRITE IN THIS AREA



SERIAL #

COMPLETE MARK ●

EXAMPLES OF
INCOMPLETE MARKS



You must use a No. 2 pencil and marks must be complete. Do not use a mechanical pencil. It is very important that you fill in the entire circle darkly and completely. If you change your response, erase as completely as possible. Incomplete marks or erasures may affect your score.

SECTION
8

- | | | | | | | | |
|----|-----------|----|-----------|----|-----------|----|-----------|
| 1 | A B C D E | 11 | A B C D E | 21 | A B C D E | 31 | A B C D E |
| 2 | A B C D E | 12 | A B C D E | 22 | A B C D E | 32 | A B C D E |
| 3 | A B C D E | 13 | A B C D E | 23 | A B C D E | 33 | A B C D E |
| 4 | A B C D E | 14 | A B C D E | 24 | A B C D E | 34 | A B C D E |
| 5 | A B C D E | 15 | A B C D E | 25 | A B C D E | 35 | A B C D E |
| 6 | A B C D E | 16 | A B C D E | 26 | A B C D E | 36 | A B C D E |
| 7 | A B C D E | 17 | A B C D E | 27 | A B C D E | 37 | A B C D E |
| 8 | A B C D E | 18 | A B C D E | 28 | A B C D E | 38 | A B C D E |
| 9 | A B C D E | 19 | A B C D E | 29 | A B C D E | 39 | A B C D E |
| 10 | A B C D E | 20 | A B C D E | 30 | A B C D E | 40 | A B C D E |

SECTION
9

- | | | | | | | | |
|----|-----------|----|-----------|----|-----------|----|-----------|
| 1 | A B C D E | 11 | A B C D E | 21 | A B C D E | 31 | A B C D E |
| 2 | A B C D E | 12 | A B C D E | 22 | A B C D E | 32 | A B C D E |
| 3 | A B C D E | 13 | A B C D E | 23 | A B C D E | 33 | A B C D E |
| 4 | A B C D E | 14 | A B C D E | 24 | A B C D E | 34 | A B C D E |
| 5 | A B C D E | 15 | A B C D E | 25 | A B C D E | 35 | A B C D E |
| 6 | A B C D E | 16 | A B C D E | 26 | A B C D E | 36 | A B C D E |
| 7 | A B C D E | 17 | A B C D E | 27 | A B C D E | 37 | A B C D E |
| 8 | A B C D E | 18 | A B C D E | 28 | A B C D E | 38 | A B C D E |
| 9 | A B C D E | 19 | A B C D E | 29 | A B C D E | 39 | A B C D E |
| 10 | A B C D E | 20 | A B C D E | 30 | A B C D E | 40 | A B C D E |

Quality
Assurance
Mark

SECTION
10

- | | | | | | | | |
|----|-----------|----|-----------|----|-----------|----|-----------|
| 1 | A B C D E | 11 | A B C D E | 21 | A B C D E | 31 | A B C D E |
| 2 | A B C D E | 12 | A B C D E | 22 | A B C D E | 32 | A B C D E |
| 3 | A B C D E | 13 | A B C D E | 23 | A B C D E | 33 | A B C D E |
| 4 | A B C D E | 14 | A B C D E | 24 | A B C D E | 34 | A B C D E |
| 5 | A B C D E | 15 | A B C D E | 25 | A B C D E | 35 | A B C D E |
| 6 | A B C D E | 16 | A B C D E | 26 | A B C D E | 36 | A B C D E |
| 7 | A B C D E | 17 | A B C D E | 27 | A B C D E | 37 | A B C D E |
| 8 | A B C D E | 18 | A B C D E | 28 | A B C D E | 38 | A B C D E |
| 9 | A B C D E | 19 | A B C D E | 29 | A B C D E | 39 | A B C D E |
| 10 | A B C D E | 20 | A B C D E | 30 | A B C D E | 40 | A B C D E |



ESSAY

Unauthorized copying or reuse of
any part of this page is illegal.

ESSAY



ESSAY

Time — 25 minutes

Turn to page 2 of your answer sheet to write your ESSAY.

The essay gives you an opportunity to show how effectively you can develop and express ideas. You should, therefore, take care to develop your point of view, present your ideas logically and clearly, and use language precisely.

Your essay must be written on the lines provided on your answer sheet—you will receive no other paper on which to write. You will have enough space if you write on every line, avoid wide margins, and keep your handwriting to a reasonable size. Remember that people who are not familiar with your handwriting will read what you write. Try to write or print so that what you are writing is legible to those readers.

Important Reminders:

- **A pencil is required for the essay.** An essay written in ink will receive a score of zero.
- **Do not write your essay in your test book.** You will receive credit only for what you write on your answer sheet.
- **An off-topic essay will receive a score of zero.**
- **If your essay does not reflect your original and individual work, your test scores may be canceled.**

You have twenty-five minutes to write an essay on the topic assigned below.

Think carefully about the issue presented in the following excerpt and the assignment below.

A colleague of the great scientist James Watson remarked that Watson was always “lounging around, arguing about problems instead of doing experiments.” He concluded that “There is more than one way of doing good science.” It was Watson’s form of idleness, the scientist went on to say, that allowed him to solve “the greatest of all biological problems: the discovery of the structure of DNA.” It is a point worth remembering in a society overly concerned with efficiency.

Adapted from John C. Polanyi, “Understanding Discovery”

Assignment: Do people accomplish more when they are allowed to do things in their own way? Plan and write an essay in which you develop your point of view on this issue. Support your position with reasoning and examples taken from your reading, studies, experience, or observations.

BEGIN WRITING YOUR ESSAY ON PAGE 2 OF THE ANSWER SHEET.

**If you finish before time is called, you may check your work on this section only.
Do not turn to any other section in the test.**



SECTION 2

Time — 25 minutes
20 Questions

Turn to Section 2 (page 4) of your answer sheet to answer the questions in this section.

Directions: For this section, solve each problem and decide which is the best of the choices given. Fill in the corresponding circle on the answer sheet. You may use any available space for scratchwork.

Notes

- The use of a calculator is permitted.
- All numbers used are real numbers.
- Figures that accompany problems in this test are intended to provide information useful in solving the problems. They are drawn as accurately as possible EXCEPT when it is stated in a specific problem that the figure is not drawn to scale. All figures lie in a plane unless otherwise indicated.
- Unless otherwise specified, the domain of any function f is assumed to be the set of all real numbers x for which $f(x)$ is a real number.

Reference Information

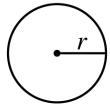

$$A = \pi r^2$$

$$C = 2\pi r$$

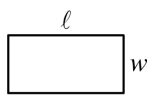

$$A = \ell w$$

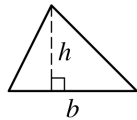

$$A = \frac{1}{2}bh$$

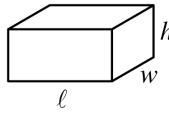

$$V = \ell wh$$

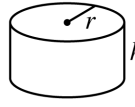

$$V = \pi r^2 h$$

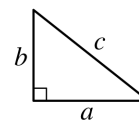

$$c^2 = a^2 + b^2$$

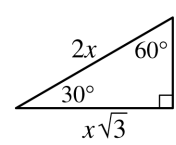

Special Right Triangles

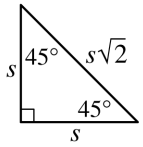

The number of degrees of arc in a circle is 360.

The sum of the measures in degrees of the angles of a triangle is 180.

- When 70,000 is written as 7.0×10^n , what is the value of n ?
 - 1
 - 2
 - 3
 - 4
 - 5
- On a car trip Sam drove m miles, Kara drove twice as many miles as Sam, and Darin drove 20 fewer miles than Kara. In terms of m , how many miles did Darin drive?
 - $2m + 20$
 - $2m - 20$
 - $\frac{m}{2} + 20$
 - $\frac{m + 20}{2}$
 - $\frac{m}{2} - 20$
- If x and y are positive integers, what are all the solutions (x, y) of the equation $3x + 2y = 11$?
 - (1,4) only
 - (3,1) only
 - (1,4) and (2,2)
 - (1,4) and (3,1)
 - (2,2) and (3,1)

GO ON TO THE NEXT PAGE 



4. A company's profit, P , in dollars, for producing x machines in one day is given by $P = 500x - 20x^2$. If the company produces 10 machines in one day, then, according to this formula, what is the profit for that day?
- (A) \$5,000
(B) \$4,000
(C) \$3,000
(D) \$2,000
(E) \$1,000

$$12 - n, 12, 12 + n$$

5. What is the average (arithmetic mean) of the 3 quantities in the list above?
- (A) 4
(B) 12
(C) 18
(D) $4 + \frac{n}{3}$
(E) $12 + \frac{n}{3}$

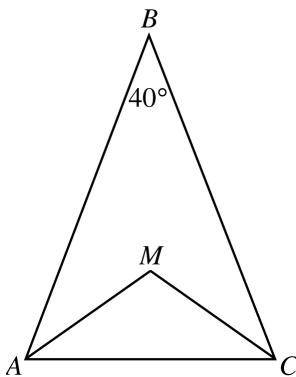

6. In isosceles triangle ABC above, \overline{AM} and \overline{CM} are the angle bisectors of angle BAC and angle BCA . What is the measure of angle AMC ?
- (A) 110°
(B) 115°
(C) 120°
(D) 125°
(E) 130°

7. A fruit salad is made from pineapples, pears, and peaches mixed in the ratio of 2 to 3 to 5, respectively, by weight. What fraction of the mixture by weight is pineapple?
- (A) $\frac{1}{5}$
(B) $\frac{3}{10}$
(C) $\frac{2}{5}$
(D) $\frac{1}{2}$
(E) $\frac{2}{3}$

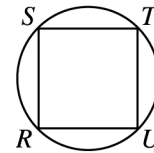

8. In the figure above, square $RSTU$ is inscribed in the circle. What is the degree measure of arc \widehat{ST} ?
- (A) 45°
(B) 60°
(C) 90°
(D) 120°
(E) 180°

-
9. If P and Q are two sets of numbers, and if every number in P is also in Q , which of the following CANNOT be true?
- (A) 4 is in both P and Q .
(B) 5 is in neither P nor Q .
(C) 6 is in P , but not in Q .
(D) 7 is in Q , but not in P .
(E) If 8 is not in Q , then 8 is not in P .



10. What is the maximum number of rectangular blocks measuring 3 inches by 2 inches by 1 inch that can be packed into a cube-shaped box whose interior measures 6 inches on an edge?

(A) 24
(B) 28
(C) 30
(D) 36
(E) 40

11. If $a \neq 0$ and $\frac{5}{x} = \frac{5+a}{x+a}$, what is the value of x ?

(A) -5
(B) -1
(C) 1
(D) 2
(E) 5

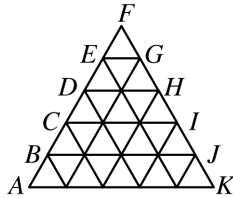

12. The figure above is composed of 25 small triangles that are congruent and equilateral. If the area of $\triangle DFH$ is 10, what is the area of $\triangle AFK$?

(A) 40
(B) 42.5
(C) 50
(D) 52.5
(E) 62.5

$$3x + 2y + 2z = 19$$

$$3x + y + z = 14$$

13. If the equations above are true, which of the following is the value of $y + z$?

(A) -5
(B) -4
(C) 0
(D) 4
(E) 5

14. A boat costs x dollars, and this cost is to be shared equally by a group of people. In terms of x , how many dollars less will each person contribute if there are 4 people in the group instead of 3?

(A) $\frac{x}{12}$
(B) $\frac{x}{4}$
(C) $\frac{x}{3}$
(D) $\frac{7x}{12}$
(E) $7x$

15. If $y = 2x + 3$ and $x < 2$, which of the following represents all the possible values for y ?

(A) $y < 7$
(B) $y > 7$
(C) $y < 5$
(D) $y > 5$
(E) $5 < y < 7$

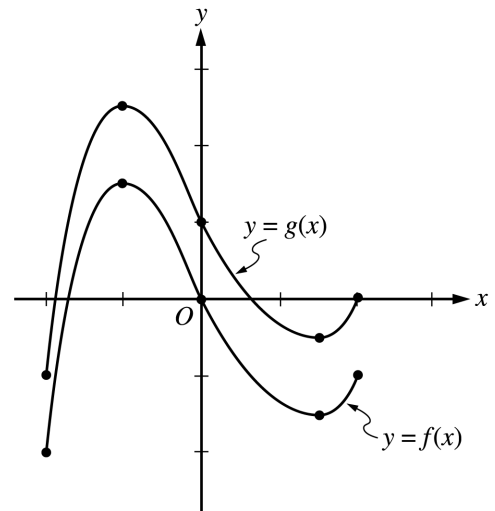

16. The graphs of the functions f and g in the interval from $x = -2$ to $x = 2$ are shown above. Which of the following could express g in terms of f ?

(A) $g(x) = f(x + 1)$
(B) $g(x) = f(x) + 1$
(C) $g(x) = f(x + 1) + 1$
(D) $g(x) = f(x - 1)$
(E) $g(x) = f(x) - 1$

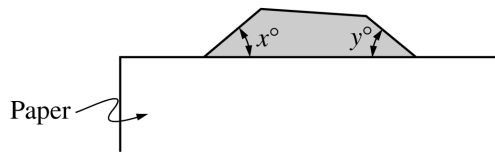

17. In the figure above, a shaded polygon which has equal sides and equal angles is partially covered with a sheet of blank paper. If $x + y = 80$, how many sides does the polygon have?

(A) Ten
(B) Nine
(C) Eight
(D) Seven
(E) Six

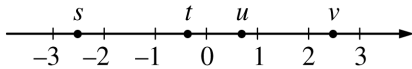

18. If s , t , u , and v are the coordinates of the indicated points on the number line above, which of the following is greatest?

(A) $|s + t|$
(B) $|s + v|$
(C) $|s - t|$
(D) $|s - v|$
(E) $|s + u|$

DEPTH OF THE WINDING RIVER

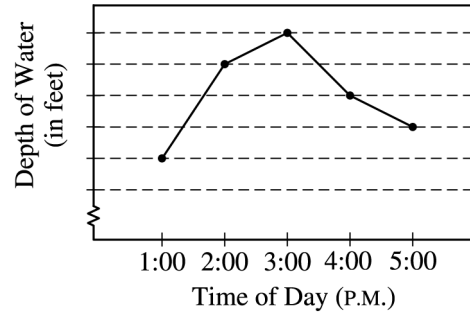

19. On the day of a rainstorm, the depth of the water at a certain location along the Winding River was recorded hourly, and the results are indicated in the line graph above. Each unit on the vertical axis represents 1 foot. If the depth of the water decreased 10 percent from 3:00 P.M. to 4:00 P.M., what was the depth of the water at 4:00 P.M.?

(A) 3 feet
(B) 15 feet
(C) 18 feet
(D) 20 feet
(E) 30 feet

20. For all numbers a and b , let $a \odot b$ be defined by $a \odot b = ab + a + b$. For all numbers x , y , and z , which of the following must be true?

I. $x \odot y = y \odot x$
 II. $(x - 1) \odot (x + 1) = (x \odot x) - 1$
 III. $x \odot (y + z) = (x \odot y) + (x \odot z)$

(A) I only
(B) II only
(C) III only
(D) I and II only
(E) I, II, and III

STOP

If you finish before time is called, you may check your work on this section only.
Do not turn to any other section in the test.

**SECTION 4**

Time — 25 minutes

24 Questions

Turn to Section 4 (page 5) of your answer sheet to answer the questions in this section.**Directions:** For each question in this section, select the best answer from among the choices given and fill in the corresponding circle on the answer sheet.

Each sentence below has one or two blanks, each blank indicating that something has been omitted. Beneath the sentence are five words or sets of words labeled A through E. Choose the word or set of words that, when inserted in the sentence, best fits the meaning of the sentence as a whole.

Example:

Hoping to ----- the dispute, negotiators proposed a compromise that they felt would be ----- to both labor and management.

- (A) enforce . . useful
(B) end . . divisive
(C) overcome . . unattractive
(D) extend . . satisfactory
(E) resolve . . acceptable

(A) (B) (C) (D) ●

- Some fans feel that sports events are ----- only when the competitors are of equal ability, making the outcome of the game -----.
(A) successful . . assured
(B) boring . . questionable
(C) dull . . foreseen
(D) interesting . . predictable
(E) exciting . . uncertain
- Alfred Schnittke's musical compositions are -----: phrases are clipped, broken into sections, and split apart by long rests.
(A) garnished (B) improvisational
(C) fragmented (D) cautious (E) uniform
- The consumer advocate claimed that while drug manufacturers ----- the supposed advantages of their proprietary brands, generic versions of the same medications are often equally -----.
(A) tout . . efficacious
(B) research . . innocuous
(C) market . . prohibitive
(D) laud . . counterproductive
(E) extract . . prescriptive
- Latoya's ----- is shown by her ability to be -----: she can see her own faults more clearly than anyone else can.
(A) perceptiveness . . self-centered
(B) objectivity . . restrictive
(C) cynicism . . self-destructive
(D) open-mindedness . . complacent
(E) insightfulness . . self-critical
- The bearded dragon lizard is a voracious eater, so ----- that it will consume as many insects as possible.
(A) abstemious (B) cannibalistic (C) slovenly
(D) insatiable (E) unpalatable
- Because drummer Tony Williams paved the way for later jazz-fusion musicians, he is considered a ----- of that style.
(A) connoisseur (B) revivalist (C) beneficiary
(D) disparager (E) progenitor
- The politician's speech to the crowd was composed of nothing but -----, a bitter railing against the party's opponents.
(A) digressions (B) diatribes (C) platitudes
(D) machinations (E) acclamations
- Favoring economy of expression in writing, the professor urged students toward a ----- rather than an ----- prose style.
(A) spare . . ornate
(B) terse . . opinionated
(C) personal . . academic
(D) baroque . . embellished
(E) repetitive . . intricate

GO ON TO THE NEXT PAGE



The passages below are followed by questions based on their content; questions following a pair of related passages may also be based on the relationship between the paired passages. Answer the questions on the basis of what is stated or implied in the passages and in any introductory material that may be provided.

Questions 9-12 are based on the following passages.

Passage 1

Food has always been considered one of the most salient markers of cultural traditions. When I was a small child, food was the only thing that helped identify my family as Filipino American. We ate *pansit lug-lug* (a noodle dish) and my father put *patis* (salty fish sauce) on everything. However, even this connection lessened as I grew older. As my parents became more acculturated, we ate less typically Filipino food. When I was twelve, my mother took cooking classes and learned to make French and Italian dishes. When I was in high school, we ate chicken marsala and shrimp fra diablo more often than Filipino dishes like *pansit lug-lug*.

Passage 2

Jean Anthelme Brillat-Savarin—who in 1825 confidently announced, “Tell me what you eat, and I will tell you who you are”—would have no trouble describing cultural identities of the United States. Our food reveals us as tolerant adventurers who do not feel constrained by tradition. We “play with our food” far more readily than we preserve the culinary rules of our varied ancestors. Americans have no single national cuisine. What unites American eaters culturally is how we eat, not what we eat. As eaters, Americans mingle the culinary traditions of many regions and cultures. We are multiethnic eaters.

9. Which of the following statements best captures the relationship between the two passages?
- (A) Passage 1 notes problems for which Passage 2 proposes solutions.
 - (B) Passage 1 presents claims that are debunked by Passage 2.
 - (C) Passage 2 furnishes a larger context for the experiences described in Passage 1.
 - (D) Passage 2 provides an update of the situation depicted in Passage 1.
 - (E) Passage 2 uses material presented in Passage 1 to correct a popular misconception.

10. The author of Passage 2 would most likely regard the mother’s willingness to “make French and Italian dishes” (lines 9-10, Passage 1) as

- (A) laughably pretentious
- (B) understandably conservative
- (C) typically American
- (D) a regrettable compromise
- (E) a surprising attitude

11. The two passages differ in their discussions of food primarily in that Passage 1

- (A) considers specific dishes eaten by particular people, whereas Passage 2 comments on a culture’s general attitude toward eating
- (B) contrasts the cuisines of different cultures, whereas Passage 2 emphasizes culinary practices common to all cultures
- (C) presents an abstract theory of food, whereas Passage 2 offers a historical analysis of consumption
- (D) emphasizes the role of nostalgia in food preferences, whereas Passage 2 rejects that approach as overly sentimental
- (E) outlines some popular choices in cuisine, whereas Passage 2 underscores those that are more unusual

12. Unlike the author of Passage 2, the author of Passage 1 makes significant use of

- (A) direct quotation
- (B) sociological analysis
- (C) hypothetical assumptions
- (D) historical sources
- (E) personal experience



Questions 13-24 are based on the following passages.

The passages below discuss the possibility of locating intelligent life on other planets. Passage 1 has been adapted from a 1999 book on the history of the universe. Passage 2 was excerpted from a 2000 book on the scientific quest for extraterrestrial life.

Passage 1

Line Generations of science-fiction movies have conditioned
5 us to consider bug-eyed monsters, large-brained intellectual
humanoids, and other rather sophisticated extraterrestrial
creatures as typical examples of life outside Earth. The
reality, however, is that finding any kind of life at all, even
something as simple as bacteria, would be one of the most
exciting discoveries ever made.

The consensus within the scientific community seems to
be that we eventually will find not only life in other parts of
10 the galaxy but also intelligent and technologically advanced
life. I have to say that I disagree. While I believe we will
find other forms of life in other solar systems (if not in
our own), I also feel it is extremely unlikely that a large
number of advanced technological civilizations are out
15 there, waiting to be discovered. The most succinct support
for my view comes from Nobel laureate physicist
Enrico Fermi, the man who ran the first nuclear reaction
ever controlled by human beings. Confronted at a 1950
luncheon with scientific arguments for the ubiquity of
20 technologically advanced civilizations, he supposedly
said, "So where is everybody?"

This so-called Fermi Paradox embodies a simple logic.
Human beings have had modern science only a few hun-
dred years, and already we have moved into space. It is not
25 hard to imagine that in a few hundred more years we will
be a starfaring people, colonizing other systems. Fermi's
argument maintains that it is extremely unlikely that many
other civilizations discovered science at exactly the same
time we did. Had they acquired science even a thousand
30 years earlier than we, they now could be so much more
advanced that they would already be colonizing our solar
system.

If, on the other hand, they are a thousand years behind
us, we will likely arrive at their home planet before they
35 even begin sending us radio signals. Technological
advances build upon each other, increasing technological
abilities faster than most people anticipate. Imagine, for
example, how astounded even a great seventeenth-century
scientist like Isaac Newton would be by our current global
40 communication system, were he alive today. Where are
those highly developed extraterrestrial civilizations so dear
to the hearts of science-fiction writers? Their existence is
far from a foregone conclusion.

Passage 2

45 Although posed in the most casual of circumstances,
the Fermi Paradox has reverberated through the decades
and has at times threatened to destroy the credibility
of those scientists seriously engaged in the Search for
Extraterrestrial Intelligence (SETI) research program.

50 One possible answer to Fermi's question ("If there are
extraterrestrials, where are they?") is that extraterrestrials
have in fact often visited Earth, and continue to do so.
This is the answer of those who believe in the existence
of unidentified flying objects, or UFO's. But few scien-
tists, even those engaged in SETI, take the UFO claims
55 seriously. "You won't find anyone around here who
believes in UFO's," says Frank Drake, a well-known
SETI scientist. If one discounts the UFO claims, yet still
believes that there are many technological civilizations in
the galaxy, why have they not visited us? Drake's answer
60 is straightforward: "High-speed interstellar travel is so
demanding of resources and so hazardous that intelligent
civilizations don't attempt it." And why should they
attempt it, when radio communication can supply all
the information they might want?

65 At first glance, Drake's argument seems very persua-
sive. The distances between stars are truly immense.
To get from Earth to the nearest star and back, traveling
at 99 percent of the speed of light, would take 8 years.
And SETI researchers have shown that, to accelerate
70 a spacecraft to such a speed, to bring it to a stop, and
to repeat the process in the reverse direction, would
take almost unimaginable amounts of energy.

Astronomer Ben Zuckerman challenges Drake's
notion that technological beings would be satisfied with
75 radio communication. "Drake's implicit assumption is
that the only thing we're going to care about is intelli-
gent life. But what if we have an interest in simpler
life-forms? If you turn the picture around and you have
some advanced extraterrestrials looking at the Earth, until
80 the last hundred years there was no evidence of intelligent
life but for billions of years before that they could have
deduced that this was a very unusual world and that there
were probably living creatures on it. They would have had
billions of years to come investigate." Zuckerman contends
85 that the reason extraterrestrials haven't visited us is that so
few exist.



13. Which statement about the Fermi Paradox is supported by both passages?
- (A) It articulates a crucial question for those interested in the existence of extraterrestrials.
 (B) It clarifies the astronomical conditions required to sustain life on other planets.
 (C) It reveals the limitations of traditional ideas about the pace of technological change.
 (D) It demonstrates the scientific community's fascination with the concept of interstellar travel.
 (E) It suggests that advanced extraterrestrial civilizations may be uninterested in our culture.
14. Which statement best describes a significant difference between the two passages?
- (A) Passage 1 analyzes a literary form, while Passage 2 argues that literature has little bearing on science.
 (B) Passage 1 presents an argument, while Passage 2 surveys current opinion in a debate.
 (C) Passage 1 concludes by rejecting the Fermi Paradox, while Passage 2 opens by embracing it.
 (D) Passage 1 describes a phenomenon, while Passage 2 details a belief system that would reject such a phenomenon.
 (E) Passage 1 defends a viewpoint, while Passage 2 questions that viewpoint's place in scientific research.
15. The author of Passage 1 mentions "monsters," "humanoids," and "creatures" (lines 2-4) primarily to
- (A) question the literary value of science fiction
 (B) contrast fictional notions with a scientific perspective
 (C) offer examples of the human fear of the unknown
 (D) criticize science fiction for being unduly alarmist
 (E) suggest that scientific research has been influenced by science fiction
16. In line 17, "ran" most nearly means
- (A) fled
 (B) accumulated
 (C) traversed
 (D) managed
 (E) incurred
17. Passage 1 suggests that the Fermi Paradox depends most directly on which assumption?
- (A) Extraterrestrial civilizations may not wish to be discovered by human beings.
 (B) Extraterrestrial civilizations would most likely have discovered technology at about the same time human beings discovered it.
 (C) Extraterrestrial technology would develop at roughly the same rate as human technology.
 (D) Extraterrestrial civilizations would inevitably use technology for aggressive ends.
 (E) Science is a more powerful form of human knowledge than are art and literature.
18. The claim made in Passage 1 that a "consensus" exists (lines 8-11) would most likely be interpreted by the author of Passage 2 as
- (A) evidence of compromise in the scientific community
 (B) an attack on SETI researchers
 (C) support for Fermi's analysis
 (D) a revelation of an unexpected truth
 (E) an oversimplification of a complex debate
19. The author of Passage 1 mentions Isaac Newton (lines 37-40) in order to
- (A) emphasize the rapid rate of technological innovation
 (B) acknowledge the impact of a profound thinker
 (C) criticize the inflexibility of Newton's contemporaries
 (D) speculate about Newton's influence on current research
 (E) highlight the value of scientific curiosity
20. In lines 44-48, the author of Passage 2 indicates that the Fermi Paradox has been
- (A) thoroughly misunderstood
 (B) surprisingly influential
 (C) overwhelmingly perplexing
 (D) intermittently popular
 (E) frequently misquoted



21. How would Frank Drake (line 56, Passage 2) most likely respond to the statement by the author of Passage 1 about humans “colonizing other systems” (line 26) ?
- (A) The means to accomplish such a project may be beyond our reach.
 (B) Interstellar colonization is as morally problematic as was colonization on Earth.
 (C) We would do better to study indigenous life-forms rather than search for extraterrestrial creatures.
 (D) Humans would be wise to consider that they themselves are subject to colonization.
 (E) Funding for such an undertaking would pose a thorny political issue for any government.
22. In line 57, “claims” most nearly means
- (A) demands
 (B) assertions
 (C) rights
 (D) territories
 (E) compensations
23. In line 63, “radio communication” is cited as a
- (A) complex interaction
 (B) technological relic
 (C) common occurrence
 (D) practical alternative
 (E) dramatic advance
24. Both the author of Passage 1 and Ben Zuckerman (line 73, Passage 2) imply that researchers seeking life on another planet should focus on which of the following?
- (A) Seasonal variations in color due to plant life
 (B) Evidence of the most basic forms of life
 (C) Signs of artificially created structures
 (D) Signals that might be radio communications
 (E) Changes in geological surface features

NOTE: The reading passages in this test are generally drawn from published works, and this material is sometimes adapted for testing purposes. The ideas contained in the passages do not necessarily represent the opinions of the College Board.

S T O P

If you finish before time is called, you may check your work on this section only.
 Do not turn to any other section in the test.

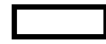
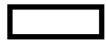
**SECTION 5**

Time — 25 minutes

35 Questions

Turn to Section 5 (page 5) of your answer sheet to answer the questions in this section.**Directions:** For each question in this section, select the best answer from among the choices given and fill in the corresponding circle on the answer sheet.

The following sentences test correctness and effectiveness of expression. Part of each sentence or the entire sentence is underlined; beneath each sentence are five ways of phrasing the underlined material. Choice A repeats the original phrasing; the other four choices are different. If you think the original phrasing produces a better sentence than any of the alternatives, select choice A; if not, select one of the other choices.

In making your selection, follow the requirements of standard written English; that is, pay attention to grammar, choice of words, sentence construction, and punctuation. Your selection should result in the most effective sentence—clear and precise, without awkwardness or ambiguity.

EXAMPLE:

Laura Ingalls Wilder published her first book and she was sixty-five years old then.

- (A) and she was sixty-five years old then
- (B) when she was sixty-five
- (C) at age sixty-five years old
- (D) upon the reaching of sixty-five years
- (E) at the time when she was sixty-five

(A) (B) (C) (D) (E)

1. The library is older than it but still just as beautiful as the courthouse.
- (A) older than it but still just as beautiful as the courthouse
 - (B) older and it is just as beautiful as the courthouse
 - (C) older than the courthouse; it is just as beautiful as it
 - (D) older than the courthouse but just as beautiful
 - (E) just as beautiful as the courthouse and it is older than it

2. Winslow Homer, one of America's foremost artists, spent his last 27 years and painted on the scenic Maine coast.

- (A) spent his last 27 years and painted
- (B) spent his last 27 years having painted
- (C) spent his last 27 years painting
- (D) having spent his last 27 years doing his painting
- (E) spending his last 27 years painting

3. Researchers are experimenting with various techniques for preventing the accumulation in water of high levels of nitrogen, which can kill plants and animals.

- (A) nitrogen, which can kill plants and animals
- (B) nitrogen; plants and animals can be killed
- (C) nitrogen, that is what can kill plants and animals
- (D) nitrogen, they could kill plants and animals
- (E) nitrogen, and they can kill plants and animals

4. When the news spread how new goldfields were discovered in Nome, Alaska, thousands abandoned Dawson, the site of the previous gold rush.

- (A) how new goldfields were discovered
- (B) how there was discovery of new goldfields
- (C) about new goldfields, which they discovered
- (D) about new goldfields, and they were discovered
- (E) about new goldfields that had been discovered

5. When the Berlin Wall, long a symbol of the Cold War, began to be torn down in 1989, five million people went to Berlin to celebrate that.

- (A) to celebrate that
- (B) for its celebration
- (C) to celebrate
- (D) in celebration of that
- (E) in celebrating

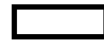
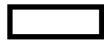

6. To complete the music program, a student must present one vocal performance, one instrumental performance, and composing one original work.
- (A) and composing one original work
(B) and one original composition
(C) with one original composition
(D) and to compose one original work
(E) as well as the student's original composition
7. Zookeepers have expanded one's definition of care to include concern for the animal's mental state as well as for its physical well-being.
- (A) have expanded one's definition of care to include
(B) have expanded one's definition of care, including
(C) expand their definition of care, they include
(D) expanding the definition of care to include
(E) have expanded their definition of care to include
8. The time and the place for such a large event is subject to approving from the mayor's office.
- (A) The time and the place for such a large event is subject to approving from the mayor's office.
(B) For such a large event, the time and the place are subject to the mayor's office's approving them.
(C) The time and the place for such a large event are subject to the approval of the mayor's office.
(D) The time and place for such a large event are subject to be approved by the office of the mayor.
(E) Subject to the approval of the mayor's office are the time and place for such a large event taking place.
9. New Zealand's Kaikoura Peninsula, a ruggedly beautiful spit of land, borders an undersea canyon that is home to the sperm whale and the giant squid.
- (A) borders an undersea canyon that is
(B) bordering an undersea canyon,
(C) and it borders an undersea canyon, which is
(D) which borders an undersea canyon,
(E) is the border of an undersea canyon, being
10. In similarity with some other great works, the enduring horror tale *Frankenstein* was first published anonymously; its author, Mary Shelley, wrote the novel when she was not quite nineteen years old.
- (A) In similarity with
(B) As
(C) Like what happened with
(D) Like the case with
(E) Like
11. The book is useful because it offers not just philosophy and theory but also tells you what and how to live every day.
- (A) but also tells you what and how to live every day
(B) but also it gives ways of everyday living
(C) but also advice for everyday living
(D) but also it gives practical advice for everyday life
(E) and also tells you what to do and how to live every day

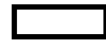
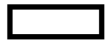

The following sentences test your ability to recognize grammar and usage errors. Each sentence contains either a single error or no error at all. No sentence contains more than one error. The error, if there is one, is underlined and lettered. If the sentence contains an error, select the one underlined part that must be changed to make the sentence correct. If the sentence is correct, select choice E. In choosing answers, follow the requirements of standard written English.

EXAMPLE:

The other delegates and him immediately
 A B C
 accepted the resolution drafted by the
 D
 neutral states. No error
 E

(A) ● (C) (D) (E)

12. The country found that its economy was growing
 A
more stronger, with an improved outlook and more
 B C
 opportunities for training and employment. No error
 D E
13. The iris, the colored part of the eye, contains delicate
 A
 patterns that are unique to each person, offering a
 B C
 powerful means of identification. No error
 D E

14. The newly elected Prime Minister, to the dismay
 A B
 of opponents from other parties, have argued for
 C
the strict regulation of campaign financing. No error
 D E
15. Studies have suggested that eating nuts—almonds
 A
 in particular—might help to lower blood cholesterol
 B
 levels in humans and reducing the risk of heart disease
 C
by protecting the blood vessels. No error
 D E
16. In English literature James Boswell is the prime
 A
 example of a biographer who, by ensuring the
 B
 immortality of another author, has achieved
 C
 immortality for himself. No error
 D E
17. Because the garden was untended, the windows
 A
had no shutters, and the lawn overrun by weeds,
 B C
 people passing by the old house assumed that
 D
 it was unoccupied. No error
 E

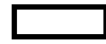
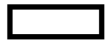

18. Until recently, most people entering politics feel that
A B
loss of privacy was a fair price to pay for the chance
C D
to participate in policy making. No error
E
19. Only by tapping their last reserves of energy were the
A B
team members able to salvage what was beginning
C D
to look like a lost cause. No error
E
20. When Doris Lessing published *The Golden Notebook*
in 1962, it instantly established herself as one of
A B C
the most important literary voices of her generation.
D
No error
E
21. Not many authors have described the effects
A B
of environmental pollution as effective as
C
Rachel Carson, whose work is still a model for
D
nature writers. No error
E
22. It was a Chinese American grower who finally
A
succeeded with adapting the now familiar
B C
orange tree to the American climate. No error
D E
23. The survey indicated that workers in the United States
hope that his or her wages will keep pace with
A B C
the rising cost of living. No error
D E
24. In Angkor, Cambodia's ancient city, a clever
A
designed reservoir, five miles long and one mile wide,
supplied fish and helped farmers to produce
B C D
three crops of rice annually. No error
E
25. Last summer, when Mary's aunt and uncle
flew from Turkey to visit their relatives and tour
A B
the United States, Mary invited Sandhya and I to
C
her house to meet them. No error
D E

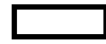
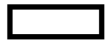

26. Ongoing research by several scientists suggest that
 A B
 regular periods of meditation reduce blood pressure
 C
 and are likely to contribute to other improvements
 D
 in health. No error
 E

27. Because the American Indian rodeo includes games
 and exhibitions developed as early as the seventeenth
 A
 century, they predate by a few hundred years
 B C
the form of rodeo now seen on television. No error
 D E

28. Five years in the writing, her new book is
 A
both a response to her critics' mistrust with
 B C
 her earlier findings and an elaboration of her
 D
 original thesis. No error
 E

29. Despite its cultural importance, the *Daily Gazette*
 A
lost 70 percent of its subscribers since 1920 and,
 B
 by 1955, was losing as much as \$200,000 a year.
 C D
No error
 E

Directions: The following passage is an early draft of an essay. Some parts of the passage need to be rewritten.

Read the passage and select the best answers for the questions that follow. Some questions are about particular sentences or parts of sentences and ask you to improve sentence structure or word choice. Other questions ask you to consider organization and development. In choosing answers, follow the requirements of standard written English.

Questions 30-35 are based on the following passage.

(1) No one owns Antarctica. (2) The nations of the world agreed—some of them reluctantly—that all countries would share the continent for the purposes of scientific research. (3) Governed by the Antarctic Treaty, written in 1959 and adopted in 1961, which has been signed by 27 countries. (4) Another 17 countries have agreed to abide by the treaty in order to participate in research being done in Antarctica.

(5) In Antarctica, relations among the researchers and their countries are both simpler and more complicated than in the rest of the world. (6) Relations are simpler because each country has only a few scientists on this isolated continent. (7) Treaty clauses assure that the research there is nonmilitary. (8) On the other hand, when conflicts do arise, there is no clear process for dealing with them. (9) Decisions that can make or break the preservation of Antarctica's unique environment and its scientific opportunities depend on a political system designed to have nobody in command.

(10) Clear decision making has become a more urgent challenge as more tourists are attracted to Antarctica. (11) Scientists living on Antarctica were not always as careful to preserve the pristine environment as they are now. (12) Tour operators are working with treaty members to devise regulations, and there are plans to assess the environmental impacts of tours. (13) But regulations and assessment plans may prove difficult to settle on and enforce in a place where jurisdiction is unclear.

30. What must be done to sentence 3 ?

- (A) Combine it with sentence 2, putting a comma after "research".
 (B) Begin it with the words "Antarctica is".
 (C) Replace the comma after "1961" with a semicolon.
 (D) Place the words "it was" before "written".
 (E) Change "1961, which" to "1961. It".

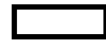
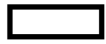

31. What should be done with sentence 7 ?

- (A) Change “assure” to “make sure”.
- (B) Change “Treaty clauses” to “The clauses agreed to by the diverse countries represented there”.
- (C) Place sentence 7 before sentence 6.
- (D) Combine sentence 7 with sentence 6 by changing the period after “continent” to a comma.
- (E) Combine sentence 7 with sentence 6 by changing “continent. Treaty” to “continent and also because treaty”.

32. In context, which is the best revision of the underlined portion of sentence 9 (reproduced below) ?

Decisions that can make or break the preservation of Antarctica’s unique environment and its scientific opportunities depend on a political system designed to have nobody in command.

- (A) create or destroy
- (B) support or dispute
- (C) be determined by
- (D) be critical to
- (E) be an adjustment to

33. The purpose of the second paragraph is to

- (A) present a situation that has contradictory elements
- (B) offer a solution to a problem discussed in the first paragraph
- (C) present an argument and its final resolution
- (D) examine a theory in light of new discoveries
- (E) discuss a theory that will be refuted in the third paragraph

34. Which sentence should be deleted?

- (A) 1
- (B) 2
- (C) 11
- (D) 12
- (E) 13

35. The third paragraph would be improved if which of the following sentences were added?

- (A) Scientists collect ice cores by driving a hollow tube deep into the miles-thick ice sheets.
- (B) If the West Antarctic ice sheet melted, global seas would rise by 15 to 20 feet.
- (C) It is the driest place in the world, yet it contains 70 percent of Earth’s freshwater.
- (D) One cruise ship encountered 30-foot waves all the way across the Drake Passage.
- (E) Last year, more than 10,000 tourists visited Antarctica, bringing soiled boots, climbing gear, and trash to many locations.

S T O P

**If you finish before time is called, you may check your work on this section only.
Do not turn to any other section in the test.**



SECTION 6

Time — 25 minutes

18 Questions

Turn to Section 6 (page 6) of your answer sheet to answer the questions in this section.

Directions: This section contains two types of questions. You have 25 minutes to complete both types. For questions 1-8, solve each problem and decide which is the best of the choices given. Fill in the corresponding circle on the answer sheet. You may use any available space for scratchwork.

Notes

- The use of a calculator is permitted.
- All numbers used are real numbers.
- Figures that accompany problems in this test are intended to provide information useful in solving the problems. They are drawn as accurately as possible EXCEPT when it is stated in a specific problem that the figure is not drawn to scale. All figures lie in a plane unless otherwise indicated.
- Unless otherwise specified, the domain of any function f is assumed to be the set of all real numbers x for which $f(x)$ is a real number.

Reference Information

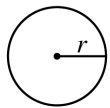

$$A = \pi r^2$$

$$C = 2\pi r$$

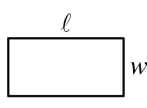

$$A = \ell w$$

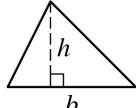

$$A = \frac{1}{2}bh$$

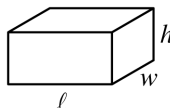

$$V = \ell wh$$

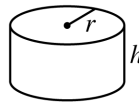

$$V = \pi r^2 h$$

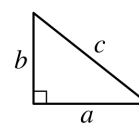

$$c^2 = a^2 + b^2$$

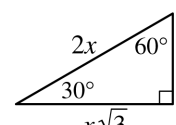

Special Right Triangles

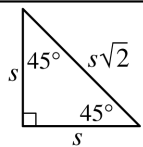

The number of degrees of arc in a circle is 360.

The sum of the measures in degrees of the angles of a triangle is 180.

- If $x + k = 12$ and $p(x + k) = 36$, what is the value of p ?
 - 3
 - 4
 - 6
 - 9
 - 12

- If 13 is added to one-half of a certain number, the result is 37. What is the original number?
 - 24
 - 40
 - 48
 - 61
 - 80

GO ON TO THE NEXT PAGE

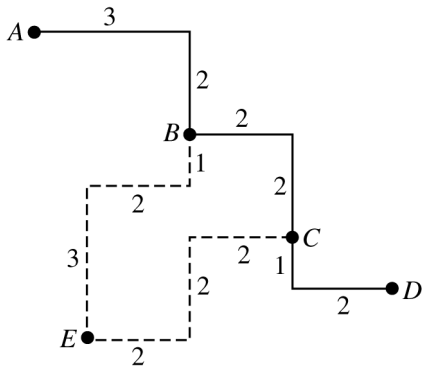

3. In the figure above, the usual route from Town A to Town D is indicated by the solid line. The broken line indicates a detour route from B to C through E . Each line segment is labeled with its length in miles. How many more miles is the trip from Town A to Town D via the detour than via the usual route?
- (A) 4
(B) 8
(C) 10
(D) 12
(E) 18

x	y
1	7.5
2	13.0
3	18.5
4	24.0

4. Which of the following equations expresses y in terms of x for each of the four pairs of values shown in the table above?
- (A) $y = 5x + 7.5$
(B) $y = 5.5x + 2$
(C) $y = 5.5x + 7.5$
(D) $y = 7.5x$
(E) $y = 7.5x + 5.5$

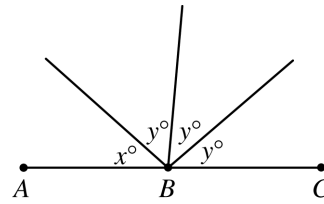

Note: Figure not drawn to scale.

5. In the figure above, point B lies on \overline{AC} . If x and y are integers, which of the following is a possible value of x ?
- (A) 30
(B) 35
(C) 40
(D) 50
(E) 55
-
6. The least and greatest numbers in a list of 7 real numbers are 2 and 20, respectively. The median of the list is 6, and the number 3 occurs most often in the list. Which of the following could be the average (arithmetic mean) of the numbers in the list?
- I. 7
II. 8.5
III. 10
- (A) I only
(B) I and II only
(C) I and III only
(D) II and III only
(E) I, II, and III



7. In the xy -coordinate plane, how many points are a distance of 4 units from the origin?
- (A) One
(B) Two
(C) Three
(D) Four
(E) More than four

Family	Number of Consecutive Nights
Jackson	10
Callan	5
Epstein	8
Liu	6
Benton	8

8. The table above shows the number of consecutive nights that each of five families stayed at a certain hotel during a 14-night period. If the Liu family's stay did not overlap with the Benton family's stay, which of the 14 nights could be a night on which only one of the five families stayed at the hotel?
- (A) The 3rd
(B) The 5th
(C) The 6th
(D) The 8th
(E) The 10th



Directions: For Student-Produced Response questions 9-18, use the grids at the bottom of the answer sheet page on which you have answered questions 1-8.

Each of the remaining 10 questions requires you to solve the problem and enter your answer by marking the circles in the special grid, as shown in the examples below. You may use any available space for scratchwork.

Write answer in boxes. →

Answer: $\frac{7}{12}$

← Fraction line

Grid in result. →

Answer: 2.5

← Decimal point

Answer: 201

Either position is correct.

Note: You may start your answers in any column, space permitting. Columns not needed should be left blank.

- Mark no more than one circle in any column.
 - Because the answer sheet will be machine-scored, **you will receive credit only if the circles are filled in correctly.**
 - Although not required, it is suggested that you write your answer in the boxes at the top of the columns to help you fill in the circles accurately.
 - Some problems may have more than one correct answer. In such cases, grid only one answer.
 - No question has a negative answer.
 - **Mixed numbers** such as $3\frac{1}{2}$ must be gridded as 3.5 or $7/2$. (If $\begin{array}{|c|c|c|c|} \hline 3 & 1 & / & 2 \\ \hline \cdot & \cdot & \cdot & \cdot \\ \hline \end{array}$ is gridded, it will be interpreted as $\frac{31}{2}$, not $3\frac{1}{2}$.)
 - **Decimal Answers:** If you obtain a decimal answer with more digits than the grid can accommodate, it may be either rounded or truncated, but it must fill the entire grid. For example, if you obtain an answer such as 0.6666..., you should record your result as .666 or .667. **A less accurate value such as .66 or .67 will be scored as incorrect.**
- Acceptable ways to grid $\frac{2}{3}$ are:
-

9. If a cake is cut into thirds and each third is cut into fourths, how many pieces of cake are there?

10. If $y = \frac{h}{x}$, where h is a constant, and if $y = 3$ when $x = 4$, what does y equal when $x = 6$?

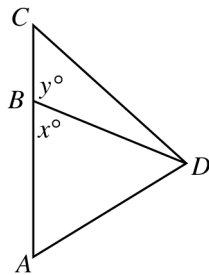

Note: Figure not drawn to scale.

11. In the figure above, point B lies on side \overline{AC} . If $55 < x < 60$, what is one possible value of y ?

12. The price of a certain item was \$10 in 1990 and it has gone up by \$2 per year since 1990. If this trend continues, in what year will the price be \$100?

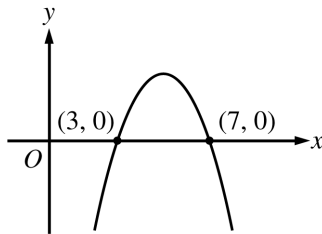

13. The figure above shows the graph of a quadratic function in the xy -plane. Of all the points (x, y) on the graph, for what value of x is the value of y greatest?

14. The number n is a 2-digit number. When n is divided by 10, the remainder is 9, and when n is divided by 9, the remainder is 8. What is the value of n ?

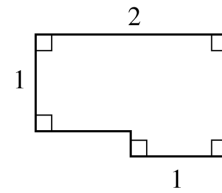

15. The area of the figure above is $\frac{9}{4}$. What is the perimeter of the figure?

16. If j is chosen at random from the set $\{4, 5, 6\}$ and k is chosen at random from the set $\{10, 11, 12\}$, what is the probability that the product of j and k is divisible by 5?

17. Tom and Alison are both salespeople. Tom's weekly compensation consists of \$300 plus 20 percent of his sales. Alison's weekly compensation consists of \$200 plus 25 percent of her sales. If they both had the same amount of sales and the same compensation for a particular week, what was that compensation, in dollars? (Disregard the dollar sign when gridding your answer.)

$$tx + 12y = -3$$

18. The equation above is the equation of a line in the xy -plane, and t is a constant. If the slope of the line is -10 , what is the value of t ?

STOP

If you finish before time is called, you may check your work on this section only.
Do not turn to any other section in the test.



SECTION 7

Time — 25 minutes

24 Questions

Turn to Section 7 (page 6) of your answer sheet to answer the questions in this section.

Directions: For each question in this section, select the best answer from among the choices given and fill in the corresponding circle on the answer sheet.

Each sentence below has one or two blanks, each blank indicating that something has been omitted. Beneath the sentence are five words or sets of words labeled A through E. Choose the word or set of words that, when inserted in the sentence, best fits the meaning of the sentence as a whole.

Example:

Hoping to ----- the dispute, negotiators proposed a compromise that they felt would be ----- to both labor and management.

- (A) enforce . . useful
- (B) end . . divisive
- (C) overcome . . unattractive
- (D) extend . . satisfactory
- (E) resolve . . acceptable

(A) (B) (C) (D) ●

1. *Black Americans in Flight*, a mural honoring several aviation pioneers, also ----- the 1992 spaceflight of astronaut Mae Jemison.
- (A) discerns
 - (B) introduces
 - (C) approximates
 - (D) commemorates
 - (E) asserts

2. The new antifungal agent has such ----- uses, from treating Dutch elm disease to rescuing water-damaged works of art from molds, that it is considered one of the more ----- antibiotics.
- (A) disturbing . . explicit
 - (B) innovative . . precipitous
 - (C) mysterious . . recognized
 - (D) varied . . versatile
 - (E) similar . . discriminating
3. The child had a tendency toward aggressive behavior, a ----- fighting rather than resolving differences amicably.
- (A) propensity for
 - (B) confusion about
 - (C) disregard of
 - (D) hostility toward
 - (E) compunction about
4. Physical exercise often has a ----- effect, releasing emotional tension and refreshing the spirit.
- (A) pejorative
 - (B) debilitating
 - (C) cathartic
 - (D) retentive
 - (E) tenacious
5. Because rap and hip-hop offer such ----- commentary on contemporary issues, they are often said to be sharp-edged musical genres.
- (A) nebulous
 - (B) trenchant
 - (C) circumspect
 - (D) prosaic
 - (E) benign



Each passage below is followed by questions based on its content. Answer the questions on the basis of what is stated or implied in each passage and in any introductory material that may be provided.

Questions 6-7 are based on the following passage.

Line “Mechanical pencils rule,” my fifteen-year-old
grandniece, Genevieve, declared when I invited her to
be her generation’s voice on school supplies. “Nobody
5 sharpens anymore.” Then, continuing with a fashion
maven’s hyperbole and arbitrary imperatives, she gave
a passionate disquisition on types of clickers, new grips,
smaller lead sizes, and other niceties of pencil selection.
As she consigned the yellow-painted wooden pencil to
10 the wastebasket of history, I felt a rush of nostalgia for
the perfumed sharpener shavings of my youth.

6. In lines 4-5, the author refers to a “fashion maven’s” tone primarily in order to
- (A) imply that Genevieve has only a superficial appreciation of mechanical pencils
 - (B) suggest that Genevieve is excessively concerned about her clothing
 - (C) illustrate some of the exaggerated claims made by mechanical pencil manufacturers
 - (D) emphasize the unpredictability of trends in consumer tastes
 - (E) indicate that Genevieve expresses her opinions with authority and flair
7. The author mentions “sharpener shavings” (line 10) in order to portray a mood of
- (A) unrestrained joy
 - (B) sentimental reminiscence
 - (C) bitter disappointment
 - (D) cautious optimism
 - (E) dark foreboding

Questions 8-9 are based on the following passage.

Line Black holes are the most efficient engines of destruction
known to humanity. Their intense gravity is a one-way
5 ticket to oblivion, and material spiraling into them can
heat up to millions of degrees and glow brightly. Yet, they
are not all-powerful. Even supermassive black holes are
minuscule by cosmic standards. They typically account for
less than one percent of their galaxy’s mass. Accordingly,
10 astronomers long assumed that supermassive holes, let
alone their smaller cousins, would have little effect beyond
their immediate neighborhoods. So it has come as a sur-
prise over the past decade that black hole activity is closely
intertwined with star formation occurring farther out in the
galaxy.

8. Which best describes the function of the statement in lines 10-13 (“So it . . . galaxy”)?
- (A) It summarizes the points made in the first four lines of the passage.
 - (B) It provides support for the argument asserted in the preceding statement.
 - (C) It introduces a new view of information presented earlier in the passage.
 - (D) It challenges recent scientific findings.
 - (E) It offers examples to support a theory.
9. Which of the following most resembles the relationship between “black hole activity” and “star formation” (lines 11-12) as described in the passage?
- (A) A volcanic eruption on one continent results in higher rainfall totals on another continent.
 - (B) Industrial emissions in one region lead to an increase in airborne pollutants in adjacent regions.
 - (C) A drought in a wilderness area causes a significant loss of vegetation in that area.
 - (D) Decreased oil production in one country results in higher gas prices in oil-dependent countries.
 - (E) Overfishing in a gulf leads to an increase in the population of smaller aquatic organisms.



Questions 10-15 are based on the following passage.

The following passage is an excerpt from a 1909 novel. Georgia, the main character, is a reporter in an otherwise all-male newsroom.

Line Georgia was to be married. It was the week before
5 Christmas, and on the last day of the year she would
become Mrs. Joseph Tank. She had told Joe that if
they were to be married at all they might as well get it
over with this year, and still there was no need of being
10 married any earlier in the year than was necessary. She
assured him that she married him simply because she was
tired of having paper bags waved before her eyes every-
where she went and she thought if she were once officially
15 associated with him people would not flaunt his idiosyn-
crasies at her that way. And then Ernestine, her best friend,
approved of getting married, and Ernestine's ideas were
usually good. To all of which Joe responded that she
certainly had a splendid head to figure it out that way.

Joe said that to his mind reasons for doing things weren't
very important anyhow; it was doing them that counted.

Yesterday had been her last day on the paper. She had
felt queer about that thing of taking her last assignment,
20 though it was hard to reach just the proper state, for the
last story related to pork-packers, and pork-packing is
not a setting favorable to sentimental regrets. It was just
like the newspaper business not even to allow one a little
sentimental harrowing over one's exodus from it. But the
25 time for gentle melancholy came later on when she was
sorting her things at her desk just before leaving, and
was wondering what girl would have that old desk—if
they cared to risk another girl, and whether the other poor
girl would slave through the years she should have been
30 frivolous, only to have some man step in at the end and
induce her to surrender the things she had gained through
sacrifice and toil.

As she wrote a final letter on her typewriter—she did
hate letting the old machine go—Georgia did considerable
35 philosophizing about the irony of working for things only
to the end of giving them up. She had waded through snow-
drifts and been drenched in pouring rains, she had been
frozen with the cold and prostrated with the heat, she had
been blown about by Chicago wind until it was strange
40 there was any of her left in one piece, she had had front
doors—yes, and back doors too—slammed in her face,
she had been the butt of the alleged wit of menials and
hirelings, she had been patronized by vapid women as
the poor girl who must make her living some way, she
45 had been roasted by—but never mind—she had had
a beat* or two! And now she was to wind it all up by
marrying Joseph Tank, who had made a great deal of

money out of the manufacture of paper bags. This from
her—who had always believed she would end her days
in New York, or perhaps write a realistic novel exposing
50 some mighty evil!

* the area regularly covered by a reporter

10. Based on information presented in the passage, which best describes what Georgia was “tired of” (line 8) ?
- (A) Being forced to earn a living
 - (B) Being teased about Joseph Tank
 - (C) Being considered a hack writer by some of her colleagues
 - (D) Being betrayed by her supposed friends
 - (E) Being the only woman in the newsroom
11. The second paragraph suggests that Georgia believes the “proper state” (line 19) would be one of
- (A) excitement
 - (B) wistfulness
 - (C) amusement
 - (D) annoyance
 - (E) relief
12. In line 27, “poor” most nearly means
- (A) pitiable
 - (B) indigent
 - (C) inferior
 - (D) humble
 - (E) petty
13. Which most resembles the “irony” mentioned in line 34 ?
- (A) A worker moving to a distant state to take a job, only to be fired without warning
 - (B) An executive making an important decision, only to regret it later
 - (C) An athlete earning a starting position on a good team, only to quit in midseason
 - (D) A student studying for a major exam, only to learn that it has been postponed
 - (E) A person purchasing an expensive umbrella, only to lose it on the first rainy day



14. The description in lines 35-45 (“She . . . two!”) primarily serves to
- (A) suggest that Georgia envied those women who did not have to work
 - (B) imply that Georgia would be unlikely ever to consider working as a reporter again
 - (C) indicate the role that weather plays in the everyday life of a reporter
 - (D) exaggerate Georgia’s reluctance to relinquish her job
 - (E) show the adversities Georgia had to overcome as a reporter

15. In context, the phrase “This from her” (lines 47-48) helps to suggest that a
- (A) specific feeling is quite heartfelt
 - (B) stated viewpoint is highly personal
 - (C) certain decision is out of character
 - (D) particular behavior is extremely upsetting
 - (E) given attitude is unsurprising



Questions 16-24 are based on the following passage.

The following passage is adapted from a book about television and popular culture.

Line
5 I suspect, though, that a lot of the fear and loathing directed at television comes out of a time-honored, reflexive overreaction to the dominant medium of the moment. For the past several decades, television has been blamed for corrupting our youth and exciting
10 our adults, distorting reality, and basically being a big, perhaps dangerous, waste of time. Before TV, radio and film were accused of the same things. And long before that—in fact, some 2,500 years earlier—philosophers were arguing that poetry and drama
15 should be excluded from any ideal city on much the same grounds.
In Book 10 of the *Republic*, Plato (428-348 B.C.) attacks epic poet Homer (c. 850 B.C.) and the tragedians on several grounds, all of which have a familiar
20 ring. “Their productions are appearances and not realities,” he gripes. “Drawing, and in fact all imitation . . . [is] quite removed from the truth.” The audience, as well as the art form, troubled Plato, whose remarks are colored by an implied disdain for the popularity of public performances.
25 The “common people,” as Plato so charitably calls them, are drawn to “peevisish and diverse” characters—such as Odysseus and other heroes in the *Iliad* and the *Odyssey*—who (to Plato, anyway) engage in such questionable displays of emotion as “spinning out a long melancholy
30 lamentation” or “disfiguring themselves in grief.” To Plato, baring such intimate sorrows is not to be condoned. (Clearly, he would have given thumbs down to the central characters of Shakespeare’s *Hamlet* and *Macbeth*.) “If you receive the pleasure-seasoned Muse¹ of song and epic,”
35 Plato warns, “pleasure and pain will be kings in your city, instead of law.” Finally, Plato sums up his anti-arts argument with the cold, sweeping pronouncement that “poetry is not to be taken seriously.”
One academic who has studied and written extensively
40 about both Plato and television suggests that Plato, rather than being anti-arts, was merely an elitist. Plato wanted to ban poetry readings and live theater, the argument goes, because, being free and accessible and raucous and extremely popular, they were the mass entertainment
45 of that era. “If, instead of ‘tragedy’ and ‘poetry,’ and ‘Homer’ and ‘Aeschylus,’² you read ‘mass entertainment’ or ‘popular media,’ you’ll recognize Plato’s arguments as the ancestor of all the reasons we have today for being suspicious of television.”
50 To wit: poetry, by which Plato means drama, confuses us between appearance and reality. The action it presents

is too extreme and violent. Most important, it’s a corrupting influence, perverting its audience by bombarding it with inferior characters and vulgar subjects—and constituting, in Plato’s own words, “a harm to the mind of its audience.”

55
60 If Plato’s *Republic* had become reality, it would have been a republic with a lot of empty libraries, theaters, and museums—if, indeed, those repositories of the arts would have survived at all. Plato’s personal utopia never came to pass—but throughout the centuries, wherever and whenever a new medium of artistic expression attracted a lot of people, someone has been ready, waiting, and eager to attack its content and fear its impact.

¹ The Muses inspired poetry and song in Greek mythology.

² Aeschylus (525-456 B.C.) was a Greek tragic dramatist.

16. The opening paragraph primarily serves to

- (A) criticize the way television distorts the truth
- (B) examine the evolution of television as a medium
- (C) place contemporary criticism of television in a historical context
- (D) directly compare television and drama as art forms
- (E) explain why television, radio, and drama appeal to the masses

17. Which of the following television shows would be LEAST vulnerable to the criticism expressed in lines 8-11 (“For . . . time”) ?

- (A) A melodrama in which police detectives attempt to solve crimes
- (B) A soap opera depicting interpersonal conflicts in a fictional law firm
- (C) A comedy whose primary characters are supernatural
- (D) A documentary on the state of education in the nation
- (E) A talk show that encourages people to confront each other in front of a studio audience

18. In line 26, “drawn” most nearly means

- (A) brought
- (B) depicted
- (C) selected
- (D) attracted
- (E) shaped



19. Which of the following best characterizes Plato's view of the heroes mentioned in line 27 ?
- (A) Admiration
 - (B) Curiosity
 - (C) Distrust
 - (D) Disappointment
 - (E) Contempt
20. The "academic" (line 39) indicates that Plato was primarily characterized by his
- (A) insight
 - (B) artistry
 - (C) cynicism
 - (D) irreverence
 - (E) snobbishness
21. The primary purpose of the statements in lines 39-45 ("One . . . that era") is to
- (A) provide an interpretation of a viewpoint described in the previous paragraph
 - (B) show how Plato's view of politics should be understood in today's terms
 - (C) put divergent interpretations of Plato into historical perspective
 - (D) account for the appeal of Plato's writings
 - (E) signal a digression in the passage
22. The fourth paragraph (lines 50-56) indicates that Plato's principal objection to "poetry" (line 50) was its
- (A) confusing language
 - (B) widespread popularity
 - (C) depiction of turbulent events
 - (D) influence on people's morals
 - (E) misrepresentation of historical figures
23. The author of the passage would probably agree with which of the following statements about the "utopia" referred to in line 60 ?
- (A) It would have encouraged new artistic ventures.
 - (B) It would have stifled human creativity.
 - (C) It is an ideal that we should continue to work towards.
 - (D) It may come to pass because of the popularity of television.
 - (E) It was a notion rejected by Greek philosophers.
24. The comment about "a new medium of artistic expression" (line 62) primarily suggests that
- (A) the author holds a fatalistic view of the future for artistic expression
 - (B) certain societies in the past have been slow to accept new art forms
 - (C) people often disguise their true feelings when it comes to art
 - (D) the popular response to a new art form will often overcome opposition to it
 - (E) a popular new art form will always receive some form of negative response

S T O P

**If you finish before time is called, you may check your work on this section only.
Do not turn to any other section in the test.**

**SECTION 8**

Time — 20 minutes

19 Questions

Turn to Section 8 (page 7) of your answer sheet to answer the questions in this section.**Directions:** For each question in this section, select the best answer from among the choices given and fill in the corresponding circle on the answer sheet.

Each sentence below has one or two blanks, each blank indicating that something has been omitted. Beneath the sentence are five words or sets of words labeled A through E. Choose the word or set of words that, when inserted in the sentence, best fits the meaning of the sentence as a whole.

Example:

Hoping to ----- the dispute, negotiators proposed a compromise that they felt would be ----- to both labor and management.

- (A) enforce . . useful
 (B) end . . divisive
 (C) overcome . . unattractive
 (D) extend . . satisfactory
 (E) resolve . . acceptable

(A) (B) (C) (D) ●

- As a child, Mary ----- her stringent upbringing; however, as she grew older she began to appreciate her grandmother's strict -----.
 (A) tolerated . . autonomy
 (B) despised . . discipline
 (C) embraced . . authority
 (D) disavowed . . abstinence
 (E) loathed . . liberality
- His mouth stinging and burning, Virgil hurried to the kitchen for water to wash away the dish's ----- taste.
 (A) earthy (B) exotic (C) cloying
 (D) acrid (E) succulent
- Since other seabirds customarily nest in colonies on ocean cliffs and islands, the marbled murrelet's ----- nesting in forests many miles from the sea must be considered -----.
 (A) ambivalence about . . hypothetical
 (B) indifference to . . bold
 (C) insistence upon . . evident
 (D) aversion to . . dangerous
 (E) predilection for . . atypical
- The cause of Mozart's ----- is a long-standing medical -----: over the years, physicians have suggested more than 100 possibilities, including poisoning, malnutrition, kidney disease, and heart failure.
 (A) mortality . . phenomenon
 (B) bereavement . . controversy
 (C) genius . . enigma
 (D) demise . . mystery
 (E) death . . trial
- At first the children were -----, but as the morning progressed they began to laugh and talk eagerly.
 (A) ostentatious (B) myopic (C) solicitous
 (D) puerile (E) reticent
- Oren missed the play's overarching significance, focusing instead on details so minor that they would best be described as -----.
 (A) pragmatic (B) indelible (C) moribund
 (D) picayune (E) impervious



The passage below is followed by questions based on its content. Answer the questions on the basis of what is stated or implied in the passage and in any introductory material that may be provided.

Questions 7-19 are based on the following passage.

The following passage is from a 1979 essay by a Native American writer.

An understanding of any national literature depends very much on an awareness of the larger cultural context. Without some knowledge of language, of history, of inflection, of the position of the storyteller within the group, without a hint of the social roles played by males and females in the culture, without a sense of the society's humor or priorities—without such knowledge, how can we, as reader or listener, penetrate to the core of meaning in an expression of art?

The difficulty of gaining access to the literature of a different culture may be illustrated by an exemplary folk-tale (in translation) from the Tanaina (Athabaskan) culture of south-central Alaska. It would typically be told to a general audience within the society, including the full range of ages from young children to grandparents; it would be recounted with gesticulation and exaggeration by a performance specialist. It would be expected to have different meanings to the various categories of listeners— instructive, entertaining, reinforcing, or all three. Here is a brief version of the story:

“Once upon a time there was a porcupine woman who decided to do some hunting on the far side of the river. She went to the bank, where she met a beaver.

‘Hello,’ she said to him. ‘I need to do some hunting over there. Will you ride me across on your back?’

‘I’d be glad to,’ replied the beaver. ‘Hop on.’

So the porcupine woman climbed on his back, and he started swimming for the other side. When he had almost made it, the porcupine woman said, ‘Oh my! I’ve forgotten to bring my sack. I’ll need to go back to the other bank and get it.’

‘All right,’ said the beaver, and swam back. He was panting while the porcupine woman went to get her sack.

‘Okay,’ she said. ‘Let’s go.’ So they started across again. The beaver was swimming much more slowly. When they had practically reached the other side, she said, ‘Oh my! I’ve forgotten to bring my needle. We’ll have to go back and get it.’

This time the beaver didn’t say anything—he didn’t have enough breath! But he turned around and pulled them back to the shore and nearly passed out while she got her needle.

‘Hurry up, now,’ the porcupine woman said as she climbed back on his back. He could hardly keep his nose above water, but he had almost made it to the far bank again when she said, ‘Oh my! I’ve forgotten my staff. We’ll have to . . .’

Before she had finished her sentence the beaver had flipped over in the water and dragged himself onto the bank, where he lay half dead. The porcupine woman managed to make the shore too, and climbed up onto a bear path. When she had caught her breath, she turned on the beaver and quilled him to death.”

The Tanaina live in an environment that could euphemistically be described as “difficult.” Survival, especially in the wild, is always precarious. Further, they were, in the precontact period, a nonliterate people. Oral communication was therefore the method of cultural transmission, legal understanding, and meaningful communication. It is also necessary to know that a “staff,” as mentioned in the story, functions as both a walking stick and a weapon, and that in the Tanaina symbol system, porcupines were supposed to be rather ponderous, dull-witted creatures, and beavers were thought to be energetic and industrious but overly spontaneous and erratic.

For the reader armed with these data, the story becomes more accessible as a lesson in contract law, with several additional minor themes. A culturally attuned listener would notice, for instance, that when the porcupine woman proposed passage to the beaver, he agreed without any stipulations or clarifications of the terms. He gave a basically open-ended agreement—made a contract—and hence the porcupine woman was perfectly within her rights both in demanding that he return three times and in quilling him to death when he reneged.

The story is not, however, without its moral for the porcupine women of this world. Her stated aim is to go hunting, and yet she sets out without the three essentials of that endeavor: a sack in which to carry home her game, a needle with which to sew up the intestines, and, most important, an implement with which to hunt and defend herself. True, she had an open-ended contract, but where does she wind up at the conclusion of the story? Sitting, exhausted, quills used up, weaponless, and not only on the wrong side of the river from her home but on a bear path! The hunter is about to become the hunted, and all because of her own improvidence.



7. In the opening paragraph, the author assumes that the “meaning” (line 8) is
- (A) culturally determined
 - (B) intensely personal
 - (C) essentially moralistic
 - (D) permanently inscrutable
 - (E) uniquely artistic
8. In the context of the passage, which “expression of art” (line 9) would be the most difficult to interpret?
- (A) A contemporary play written by a prolific playwright
 - (B) A fable from a nonliterate society with which anthropologists are very familiar
 - (C) A single text produced by a previously unknown society
 - (D) A sitcom from the early days of television
 - (E) A single myth from an ancient culture with a well-documented mythological structure
9. How does the author respond to the question posed in lines 3-9?
- (A) By proposing an innovative strategy
 - (B) By confirming the futility of such analysis
 - (C) By describing a personal experience with the problem
 - (D) By illustrating his point within a particular context
 - (E) By documenting a traditional approach to the problem
10. The author discusses Tanaina culture from the perspective of
- (A) a concerned parent
 - (B) a bewildered visitor
 - (C) a performance artist
 - (D) an informed outsider
 - (E) an indignant reader
11. The sentence in which “difficult” appears (lines 54-55) indicates that the author considers the word to be
- (A) an exaggeration
 - (B) an estimate
 - (C) an understatement
 - (D) a contradiction
 - (E) a preconception
12. In relation to the passage, the statements in lines 59-65 serve a function most similar to which of the following items?
- (A) A menu in a restaurant
 - (B) The key or legend to a map
 - (C) A department store directory
 - (D) The outline of a term paper
 - (E) An illustration of a fairytale
13. The author’s analysis of the folktale offers which insight into Tanaina beliefs?
- (A) A fanciful story is most suitable for an audience of children.
 - (B) A verbal exchange can establish a binding contract.
 - (C) A person who behaves impulsively is most often sincere.
 - (D) A shared task should be divided fairly between two people.
 - (E) A painstaking plan may nonetheless fail to anticipate all problems.
14. The “porcupine women of this world” (lines 76-77) are best described as people who
- (A) plan inadequately for their own needs
 - (B) postpone necessary work in favor of leisure
 - (C) depend heavily upon help from their close friends
 - (D) return repeatedly to their favorite places
 - (E) flee quickly from any laborious task
15. The final paragraph (lines 76-87) suggests that the bear path mentioned in lines 51-52 is significant because it
- (A) foreshadows the arrival of a benevolent character from Tanaina folklore
 - (B) suggests an alarming alternative to crossing the river
 - (C) marks the boundary of the beaver’s natural surroundings
 - (D) explains the porcupine woman’s fear of unfamiliar territory
 - (E) poses a new peril for the porcupine woman



16. In lines 83-87, the description of the porcupine woman emphasizes the discrepancy between her
- (A) social position and her private feelings
 - (B) physical wealth and her moral poverty
 - (C) hostile action and her ultimate gratitude
 - (D) original goal and her actual situation
 - (E) grandiose ambition and her real needs
17. As a commentary on legal relations, this folktale is best described as
- (A) an example of traditional practices
 - (B) an outline for social behavior
 - (C) a warning about ill-conceived assent
 - (D) a criticism of obsolete customs
 - (E) a parody of actual situations
18. The author's attitude toward the Tanaina folktale is best described as
- (A) excitement at an unexpected discovery
 - (B) admiration of the storyteller's performance
 - (C) appreciation of the folktale as a means of communicating values
 - (D) enthusiasm for the Tanaina culture's concept of legality
 - (E) enjoyment of the comical aspects of the folktale
19. Which statement is most consistent with the author's argument?
- (A) Translating a literary text requires formal linguistic training.
 - (B) Tales transmitted by a nonliterate society elude transcription in later eras.
 - (C) Listening to a skilled storyteller is more instructive than entertaining.
 - (D) Simple enjoyment of a tale is incompatible with scholarly analysis.
 - (E) To read a text is not necessarily to understand it.

S T O P

If you finish before time is called, you may check your work on this section only.
Do not turn to any other section in the test.



SECTION 9

Time — 20 minutes

16 Questions

Turn to Section 9 (page 7) of your answer sheet to answer the questions in this section.

Directions: For this section, solve each problem and decide which is the best of the choices given. Fill in the corresponding circle on the answer sheet. You may use any available space for scratchwork.

Notes

- The use of a calculator is permitted.
- All numbers used are real numbers.
- Figures that accompany problems in this test are intended to provide information useful in solving the problems. They are drawn as accurately as possible EXCEPT when it is stated in a specific problem that the figure is not drawn to scale. All figures lie in a plane unless otherwise indicated.
- Unless otherwise specified, the domain of any function f is assumed to be the set of all real numbers x for which $f(x)$ is a real number.

Reference Information

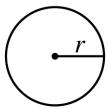

$$A = \pi r^2$$

$$C = 2\pi r$$

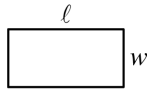

$$A = \ell w$$

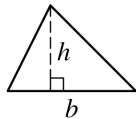

$$A = \frac{1}{2}bh$$

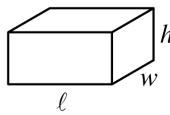

$$V = \ell wh$$

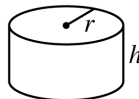

$$V = \pi r^2 h$$

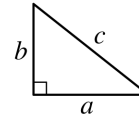

$$c^2 = a^2 + b^2$$

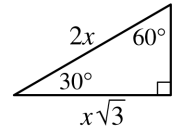

Special Right Triangles

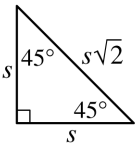

The number of degrees of arc in a circle is 360.

The sum of the measures in degrees of the angles of a triangle is 180.

1. If $\frac{1}{3}y + 9 = 0$, then $y =$

- (A) -27
(B) -9
(C) -3
(D) 3
(E) 27

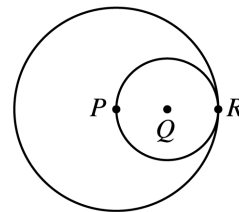

2. In the figure above, P , Q , and R lie on the same line. P is the center of the larger circle, and Q is the center of the smaller circle. If the radius of the larger circle is 4, what is the radius of the smaller circle?

- (A) 1
(B) 2
(C) 4
(D) 8
(E) 16

GO ON TO THE NEXT PAGE



3. Roy planted corn on $\frac{1}{5}$ of his land. If he planted 45 acres of corn, how many acres of land does he have?
- (A) 90
(B) $112\frac{1}{2}$
(C) 135
(D) 225
(E) $337\frac{1}{2}$

6, 10, 18, 34, 66

4. The first number in the list above is 6. Which of the following gives a rule for finding each successive number in the list?
- (A) Add 4 to the preceding number.
(B) Take $\frac{1}{2}$ of the preceding number and then add 7 to that result.
(C) Double the preceding number and then subtract 2 from that result.
(D) Subtract 2 from the preceding number and then double that result.
(E) Triple the preceding number and then subtract 8 from that result.

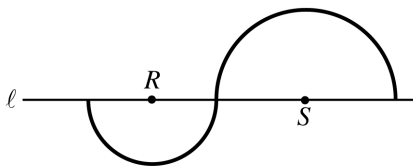

5. The two semicircles in the figure above have centers R and S , respectively. If $RS = 12$, what is the total length of the darkened curve?
- (A) 8π
(B) 9π
(C) 12π
(D) 15π
(E) 16π

6. If h and k are positive numbers and $h + k = 7$, then $\frac{7 - k}{h} =$
- (A) 1
(B) 0
(C) -1
(D) h
(E) $k - 1$

Country	Total Population	Population Density
A	6,500,000 people	600 people per square mile
B	7,600,000 people	400 people per square mile

7. The table above shows the populations of two countries and their population densities. The number of square miles in the area of Country B is approximately how much greater than the number of square miles in the area of Country A ?
- (A) 200
(B) 3,600
(C) 5,000
(D) 8,000
(E) 905,000,000

8. If $x^2 = x + 6$, which of the following must be true?
- (A) $x = 6$
(B) $x < 3$
(C) $x > 0$
(D) $x^2 < x$
(E) $x^2 > x$



9. Let the function f be defined by $f(x) = 5x - 2a$, where a is a constant. If $f(10) + f(5) = 55$, what is the value of a ?
- (A) -5
 (B) 0
 (C) 5
 (D) 10
 (E) 20

10. A number is called “even-odd” if it is halfway between an even integer and an odd integer. If x is an even-odd number, which of the following must be true?
- I. $2x$ is an integer.
 II. $2x$ is even-odd.
 III. x is halfway between two even integers.
- (A) I only
 (B) II only
 (C) I and II only
 (D) II and III only
 (E) I, II, and III

11. If m is a positive integer, which of the following is NOT equal to $(2^4)^m$?
- (A) 2^{4m}
 (B) 4^{2m}
 (C) $2^m(2^{3m})$
 (D) $4^m(2^m)$
 (E) 16^m

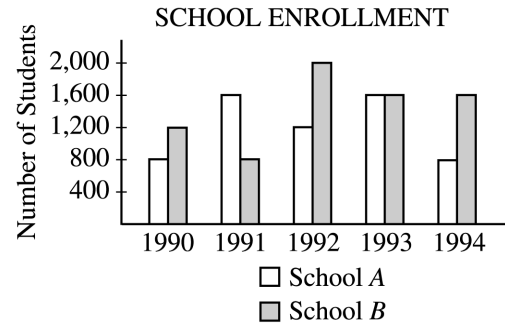

12. According to the graph above, in which year was the ratio of the number of students enrolled at School B to the number of students enrolled at School A the greatest?
- (A) 1990
 (B) 1991
 (C) 1992
 (D) 1993
 (E) 1994

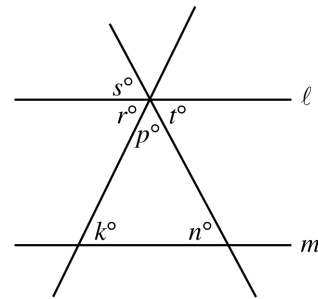

13. In the figure above, $l \parallel m$. Which of the following must equal 180?
- (A) $k + n + r$
 (B) $k + p + s$
 (C) $n + p + s$
 (D) $n + p + t$
 (E) $r + s + t$



14. How many different ordered pairs (x, y) are there such that x is an even integer, where $4 \leq x \leq 10$, and y is an integer, where $4 < y < 10$?

(A) 8
(B) 12
(C) 20
(D) 30
(E) 36

$$n(t) = 500(0.81)^t$$

15. The function above can be used to model the population of a certain endangered species of animal. If $n(t)$ gives the number of the species living t decades after the year 1900, which of the following is true about the population of the species from 1900 to 1920?

(A) It increased by about 1,000.
(B) It increased by about 320.
(C) It decreased by about 180.
(D) It decreased by about 320.
(E) It decreased by about 1,000.

16. A sphere of radius r inside a cube touches each one of the six sides of the cube. What is the volume of the cube, in terms of r ?

(A) r^3
(B) $2r^3$
(C) $4r^3$
(D) $\frac{4}{3}\pi r^3$
(E) $8r^3$

S T O P

If you finish before time is called, you may check your work on this section only.
Do not turn to any other section in the test.

SECTION 10

Time — 10 minutes

14 Questions

Turn to Section 10 (page 7) of your answer sheet to answer the questions in this section.
Directions: For each question in this section, select the best answer from among the choices given and fill in the corresponding circle on the answer sheet.

The following sentences test correctness and effectiveness of expression. Part of each sentence or the entire sentence is underlined; beneath each sentence are five ways of phrasing the underlined material. Choice A repeats the original phrasing; the other four choices are different. If you think the original phrasing produces a better sentence than any of the alternatives, select choice A; if not, select one of the other choices.

In making your selection, follow the requirements of standard written English; that is, pay attention to grammar, choice of words, sentence construction, and punctuation. Your selection should result in the most effective sentence—clear and precise, without awkwardness or ambiguity.

EXAMPLE:

Laura Ingalls Wilder published her first book and she was sixty-five years old then.

- (A) and she was sixty-five years old then
- (B) when she was sixty-five
- (C) at age sixty-five years old
- (D) upon the reaching of sixty-five years
- (E) at the time when she was sixty-five

 (A) (B) (C) (D) (E)

1. The Amazon River carries more water than the water carried in any of the world's other rivers.
 - (A) the water carried in any of the world's other rivers
 - (B) the water elsewhere in the world's rivers
 - (C) any other river in the world
 - (D) all rivers in the world
 - (E) any of the world's rivers elsewhere
2. The owners of stadiums that bear the names of now bankrupt companies have a problem what to do about the names.
 - (A) what to do about the names
 - (B) what they should do about the names
 - (C) deciding what to do about those names
 - (D) to decide as to whether the names should stay
 - (E) should they change those names or not
3. During the Fourth of July weekend in 1947, about six million people crowded onto the beach and into the amusements at Coney Island, "America's Playground," in Brooklyn, New York.
 - (A) During the Fourth of July weekend in 1947,
 - (B) It was the Fourth of July weekend in 1947 that
 - (C) The Fourth of July weekend that occurred in 1947 was when
 - (D) The Fourth of July weekend in 1947,
 - (E) Occurring in 1947 over the Fourth of July weekend,
4. Because fiscal problems will force some cities to lay off firefighters, and so the state legislature must decide whether to provide those cities with financial aid.
 - (A) firefighters, and so
 - (B) firefighters is a matter
 - (C) firefighters,
 - (D) firefighters; then
 - (E) firefighters; this is a problem
5. A recently published history of comic books reveal that *Batman* was begun as an experiment but became an institution.
 - (A) recently published history of comic books reveal that *Batman* was begun as an experiment
 - (B) recently published history of comic books reveals that *Batman* began as an experiment
 - (C) recent published history of comic books revealed that *Batman*, who began as an experiment
 - (D) history of comic books, recently published, revealing *Batman* first began as an experiment
 - (E) history of comic books having been recently published, it reveals how *Batman* began as an experiment



6. A discovery in New Jersey actually contributed to the early economic development of America and, in 1714, a worker uncovered a green rock containing copper.
- (A) America and, in 1714, a worker uncovered
 (B) America when, in 1714, a worker uncovered
 (C) America, thus, in 1714, a worker uncovered
 (D) America, that being a worker in 1714 uncovering
 (E) America, it was in 1714 a worker uncovered
7. Selected as an astronaut by NASA in 1990, over 719 hours in space were spent by Dr. Ellen Ochoa on three flights by 2001.
- (A) over 719 hours in space were spent by Dr. Ellen Ochoa on three flights by 2001
 (B) by 2001, and on three flights, Dr. Ellen Ochoa spent over 719 hours in space
 (C) three flights and 719 hours were spent by Dr. Ellen Ochoa in space by 2001
 (D) Dr. Ellen Ochoa, by 2001 spending over 719 hours in space on three flights
 (E) Dr. Ellen Ochoa had spent over 719 hours in space on three flights by 2001
8. The old maxim “Let the buyer beware” suggests that as a buyer we are responsible for inspecting merchandise for flaws before paying for it.
- (A) as a buyer we are responsible
 (B) as a buyer it is their responsibility
 (C) the buyer is the responsible one
 (D) buyers are responsible
 (E) buyers are to be the ones responsible
9. The same analysts who once favored public-opinion polls now see them as hampering representative government.
- (A) The same analysts who once favored public-opinion polls now see them
 (B) The same analysts which were once in favor of public-opinion polls now have come to see them
 (C) Public-opinion polls, once favored by analysts, but now seen by these same analysts
 (D) As for favoring public-opinion polls, the same analysts now see them
 (E) Analysts once were in favor of public-opinion polls, which these same analysts now see
10. Santa Fe is one of the oldest cities in the United States. its adobe architecture, spectacular setting, and clear, radiant light have long made it a magnet for artists.
- (A) Santa Fe is one of the oldest cities in the United States, its
 (B) Santa Fe, which is one of the oldest cities in the United States, its
 (C) Santa Fe, which is one of the oldest cities in the United States, has
 (D) Santa Fe is one of the oldest cities in the United States; its
 (E) Santa Fe, one of the oldest cities in the United States, and its
11. Dime novels, known in nineteenth-century England as “penny dreadfuls,” flourished because increased mechanization of printing and increased literacy rates made production of large numbers of these books profitable.
- (A) and increased literacy rates made
 (B) with increased literacy rates also made
 (C) and also literacy rates increased and made
 (D) as well as increased literacy rates, making
 (E) and literacy rates increased, making
12. Frequently on tour, a band called the Chieftains revered internationally as spirited performers of traditional Irish music.
- (A) revered internationally as spirited performers
 (B) revered internationally and they are spirited performers
 (C) is revered internationally for its spirited performances
 (D) is revered internationally as giving spirited performances
 (E) are revered internationally as being spirited performers



13. Psychologists advise that before making any major changes in your life, a person needs to focus on one's goals.

- (A) your life, a person needs to focus on one's goals
- (B) their life, a person needs to focus on their goals
- (C) their lives, focus on the goals
- (D) one's life, you should focus on your goals
- (E) their lives, people should focus on their goals

14. Some beaches are frequently contaminated by untreated sewage that flows into the ocean, which can last for several days.

- (A) ocean, which can last for several days
- (B) ocean that can last for several days
- (C) ocean, it can last for several days
- (D) ocean, while contamination can last several days
- (E) ocean; the contamination can last for several days

S T O P

**If you finish before time is called, you may check your work on this section only.
Do not turn to any other section in the test.**